



GRIPPER FEATURES

- » Automated finger changes in seconds with patent-pending pull stud design
- » Optional aluminum or steel finger configurations
- » Self-centering design for high force transmission and centric gripping
- » Integrated electronic sensors ensure finger position and readiness
- » Small size—perfect for maximizing small work envelopes
- » Lightweight: high-strength aluminum alloy
- » Hard-coat finish
- » Vacuum and extended-reach attachments available

Introducing the Kurt RV24 Gripper — our newest robotic end effector.

A smaller robot-ready gripper with quick-change, customizable fingers, the RV24 is perfect for cobots and smaller robots.

The new RV24 Robotic Gripper is a two-finger parallel gripper featuring Kurt's patent-pending quick-change finger design that allows automated finger/end-effector changes without additional tools or gripper body changes. Quick-change fingers are secured with pull studs and allow customers to have multiple finger options without multiple gripper bodies—saving customers money and work space.

The compact Kurt RV24 Gripper comes standard with the same great features as its larger sibling, the RV36, including integrated electronics with sensors that ensure fingers are in place, a lightweight, high-strength aluminum alloy body and a hard-coat finish to reduce wear and increases life in the field. The double-acting piston design enables dependable, repeatable clamping. Machinable aluminum or steel finger options can be cut to work in a variety of part-holding applications. Additional finger sets and gripper accessories are sold separately.

kurtworkholding.com



Kurt Manufacturing // A Full-Service Multi-Divisional Manufacturer since 1946

9445 East River Road NW | Minneapolis, MN 55433 | workholding@kurt.com | 877.226.7823

Kurt RV24 Gripper

TECHNICAL SPECIFICATIONS

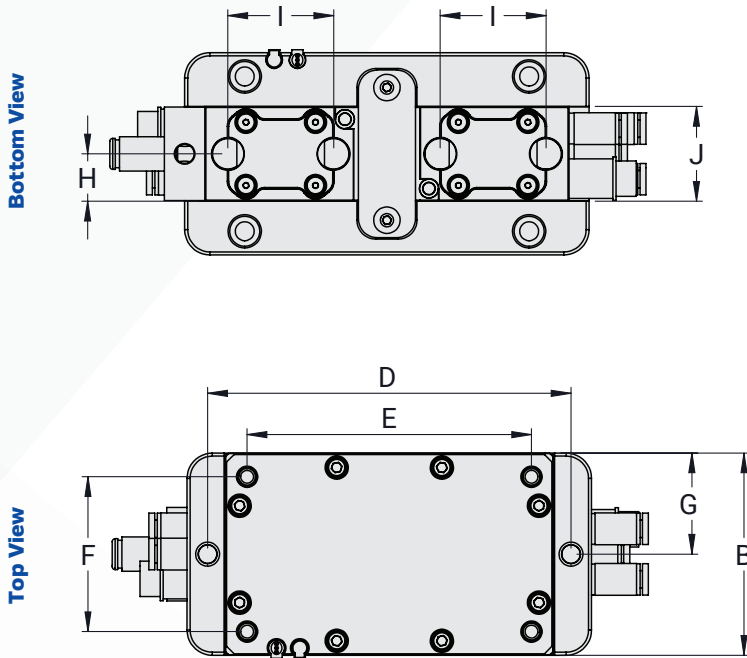

A	2.000
B	2.000
C	4.000
D	3.594
E	2.812
F	1.532
G	1.000
H	0.468
I	1.0469
J	0.936
K	1.344
L	0.938
M	1.500
N	0.227
O	0.469
MAX OPEN AA	1.00
MIN OPEN BB	0.60
ASSEMBLY WEIGHT	2.00 lbs
STEEL JAW SET WEIGHT	1.01 lbs
ALUMINUM JAW SET WEIGHT	0.38 lbs

