



KURT WORKHOLDING

DTR10

**DOVELOCK™ DOVETAIL
5 AXIS VISE**

Operating Instruction Manual
DTR10



ENGLISH

TABLE OF CONTENTS

| | |
|--------------------------------|-----|
| Introduction | 3 |
| Setup Instructions | 4 |
| Operating Instructions | 5-9 |
| DTR10 Parts List..... | 10 |
| DTR10 Mechanical Drawing | 11 |
| Maintenance Schedule | 12 |
| Troubleshooting Tips | 13 |
| Maintenance Log/Notes | 14 |
| Warranty | 15 |

WISE DATA

Use this to fill out information about your vise for quick reference.

Purchase Date: _____ - _____ - _____

Purchase Order: _____

Purchased From: _____

Delivery Date: _____

Serial No.: _____

**NOTE: MAKE SURE TO REGISTER YOUR WARRANTY ONLINE AT
KURTHOLDING.COM**

INTRODUCTION

Thank you for purchasing a Kurt DTR10 vise. You have just purchased one of the best machine vises in the industry. The outstanding accuracy of this product is second to none. Backed by a lifetime warranty against workmanship and material defects, this product is built to last when used and maintained properly.

The dovetail vise is a 5 axis vise meant for cutting dovetail parts or dovetail stock. The dovetail ensures a firm grip on the part while allowing access to the part for 5-axis machining.

The patented Anglock design allows the movable jaw to advance in such a way that each pound of force forward induces a ½ pound of force downward which minimizes the jaw lift and increases accuracy. This increases jaw clamping pressure.

Fig.1



SET-UP INSTRUCTIONS

Now that you have your new Kurt Vise, it's time to set-up and begin using it. You will see that your new vise comes with a Kurt swivel handle in the shipping carton (instruction manual available online at www.kurtworkholding.com). The handle is specifically designed to provide maximum torque to your vise (clamping force provided below). Your vise should be mounted to a clean, flat surface. The surface and the vise must be free of any chips, dirt, or debris of any kind. The mounting surface can be honed if necessary. Clean the bottom of the vise with solvent or another cleaner if needed.

To minimize vise bed deflection, clamp your Kurt vise to your machine table, pallet, or through the body holes provided.

Additional clamping can be used, but may not be necessary. Please be sure to exercise good judgment when securing your vise to the mounting surface. Be sure your vise is secured and will not move when applying the machine pressure.

| Torque Inch-Lbs. | DTR10 | Clamping Force - Lbs |
|------------------|-------|----------------------|
| 30 | | 360 |
| 60 | | 760 |
| 90 | | 1350 |
| 120 | | 1900 |
| 150 | | 2580 |
| | | |

OPERATING INSTRUCTIONS

For proper vise operation, insert the handle on to the hex end of the vise. Rotate clockwise to clamp and counterclockwise to unclamp your vise. This handle, combined with the correct amount of torque, will provide you with all the clamping force you will need to machine your parts. **DO NOT** use any other type of pressure to open or close your vise.

The uses of handle extensions, air impact wrenches, breaker bars, or hammer strikes are not recommended and will void the warranty if used. This will also cause damage to the thrust bearing and screw threads. If you need more clamping force you may require a larger vise.

To properly clamp a part in your Kurt vise, you should place the part in the center of the jaws resting on the ways of the vise. Clamping only on one side or above the movable and stationary jaws can result in jaw lift or loss of accuracy. (See Fig. 2 on next page)

If one-sided clamping is necessary, you **MUST** use a dummy part on the other side. When using parallels or step jaws, you must select a size that keeps the bottom of the clamped part at or below the top of the movable and stationary jaws. Always use jaw plates for clamping. If jaw plates are not used, damage to the mounting surface of the movable and stationary jaw will occur. This will result in reduced clamping accuracy and repeatability.

Fig.2

Sketch #2A

Incorrect part clamping.

Vise width centerline

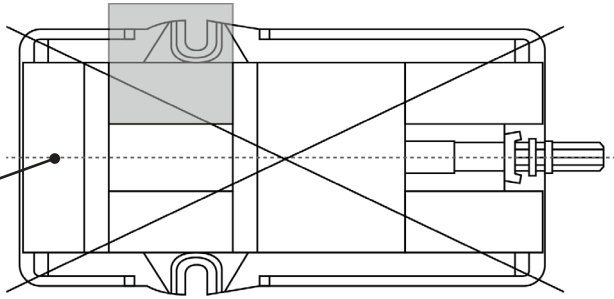

Sketch #2B

Correct part clamping.

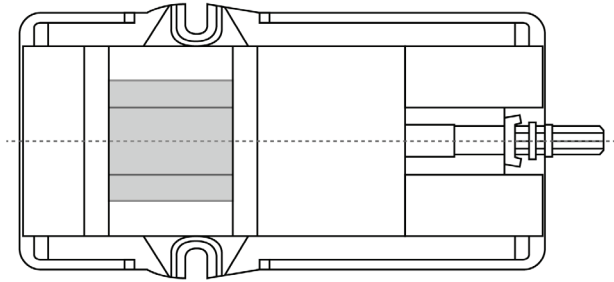

Sketch #2C

Correct part clamping.

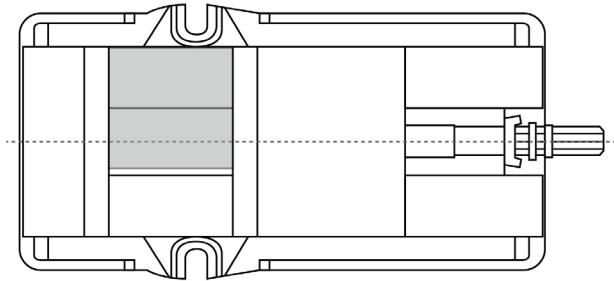

Sketch #2D

Correct part clamping.

Dummy spacer

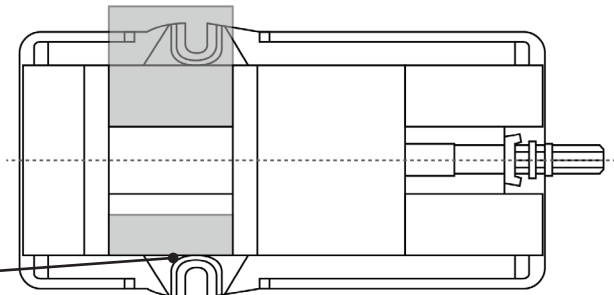

DIMENSIONAL VIEWS

Fig.4

Note: Dimensions below are in inches unless specified.

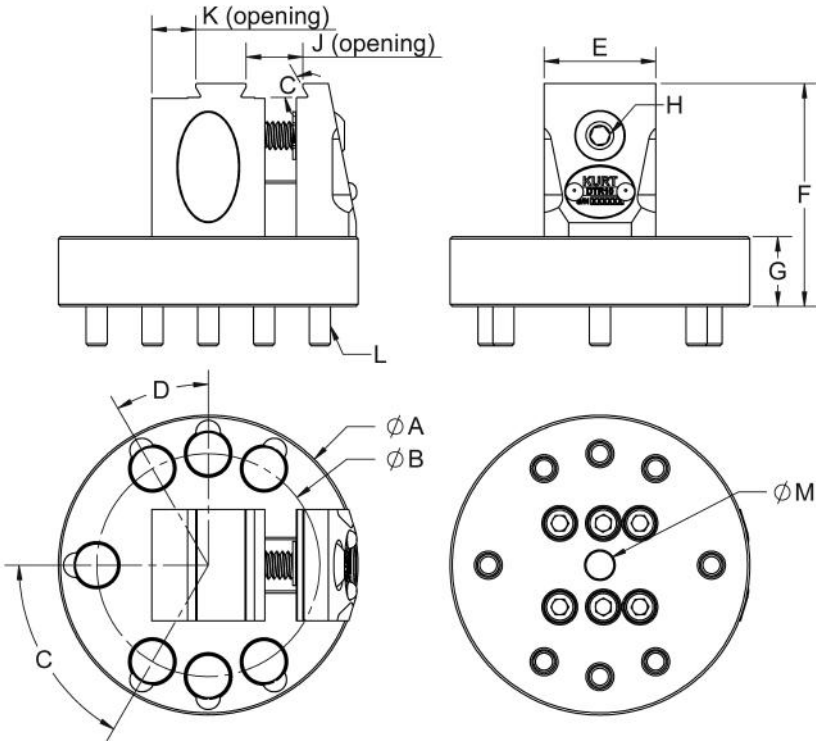

| | |
|------------------------------|-----------------|
| A | 2.69 |
| B | 2.00 |
| C | 60° |
| D | 30° |
| E | 1.00 |
| F | 2.00 |
| G | 0.625 |
| H | 1/4-20 BHSCS |
| I | 0.125 |
| J (OPENING) | 0.52-0.80 |
| K (OPENING) | 0.29 - 0.57 |
| L | 10-32 SHCS |
| ϕM (SLIP FIT DOWEL) | 0.250 |
| EST. WEIGHT | 1.5 Lbs |

SURFACE MOUNTING THE DTR10

The DTR10 can be located and mounted using a slip fit 1/4 inch center dowel pin and 10-32 socket head cap screws.

English Mounting:

The DTR10 can be properly located using the 1/4" slip fit dowel indicated by M in figure 4 above. The DTR10 can be bolted down using eight 10-32 socket head cap screws indicated in figure 4 above by L.

JAW POSITIONING

The DTR10 has reversible jaws that allow for more part size variation. See the below figure to see the two jaw configuration options and opening capabilities.

Fig.5 **Note:** Dimensions below are in inches unless specified.

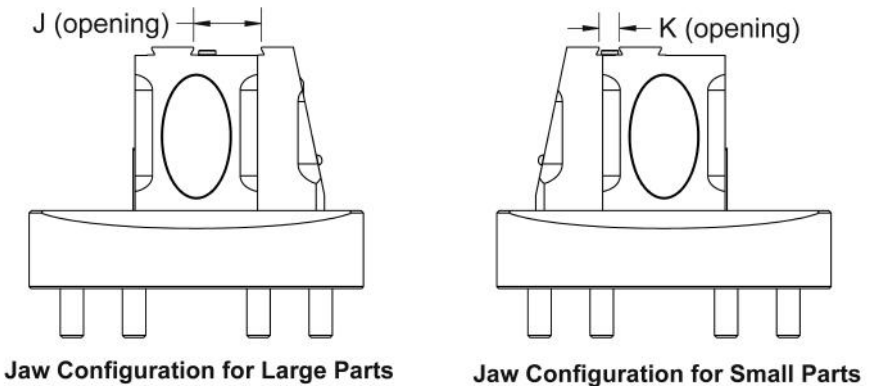

REVERSIBLE JAW INSTRUCTIONS

The DTR10 has a reversible movable jaw. Follow the directions below to reverse the jaw.

1. Loosen the set screw (#4 in figure in 7) the part of the movable jaw that protrudes through the stationary jaw. This set screw retains the movable jaw to the stationary jaw.
2. Back the screw out until the movable jaw is free from the stationary jaw.
3. Remove the protective plug assembly (#12 & #22 in figure 7) from the other side of the stationary jaw.
4. Insert the movable jaw and screw on the other side of the vise.
5. Tighten the set screw in the movable jaw so that it is retained again.
6. Insert the protective plug into the other side of the stationary jaw.

Note:

The set screw that retains the movable jaw pushes a ball into a cavity in the stationary jaw. If the set screw is tightened too hard, the ball can get stuck in that cavity. The set screw should be tightened to firmly push the ball into the cavity and then backed off about 1/4 turn. When loosening the set screw and removing the movable jaw, be careful not to lose the ball.

DTR10 Parts List

| ITEM NO. | PART NO. | DESCRIPTION | QTY. |
|----------|------------|-----------------------------------|------|
| 1 | DTR10-1 | DOVETAIL BODY BASE | 1 |
| 2 | DTR10-2-CP | DOVETAIL MOVABLE | 1 |
| 3 | DTR10-6 | DOVETAIL STATIONARY | 1 |
| 4 | DTR10-18 | BHSHCS 1/4-20 X 1.125 LG MODIFIED | 1 |
| 5 | DTR10-41 | THRUST BUSHING | 1 |
| 6 | DTR10-42 | THRUST WASHER | 2 |
| 7 | DTR10-68 | O-RING #010 | 8 |
| 8 | DTR10-97 | THREAD WIPER SEAL | 2 |
| 9 | DTR10-102 | MODEL/SERIAL NUMBER TAG | 1 |
| 10 | DTR10-147 | RETAINING RING | 2 |
| 11 | DTR10-191 | PROTECTIVE PLUG | 8 |
| 12 | 3400V-191 | PROTECTIVE PLUG | 1 |
| 13 | DTR10-231 | EXTERNAL RETAINING RING | 1 |
| 14 | DTR10-313 | WEBSITE STICKER | 1 |
| 15 | DTR10-314 | PRODUCT LOGO STICKER | 1 |
| 16 | DTR10-355 | 5/32Ø STEEL BALL | 1 |
| 17 | 00-0257 | SHCS 10-32 X .625 LG | 8 |
| 18 | 00-1195 | SHCS 8-32 X .625 LG | 6 |
| 19 | 01-3241 | 6-32 CONE POINT SET SCREW | 1 |
| 20 | 04-0016 | DOWEL PIN .125Ø X .50 LG | 2 |
| 21 | 07-0230 | U-TYPE DRIVE SCREW #2 X 1/4 L | 2 |
| 22 | 605-02 | O-RING #014 | 1 |

DTR10 Mechanical Drawing

Fig.7

14 14 NOT SHOWN

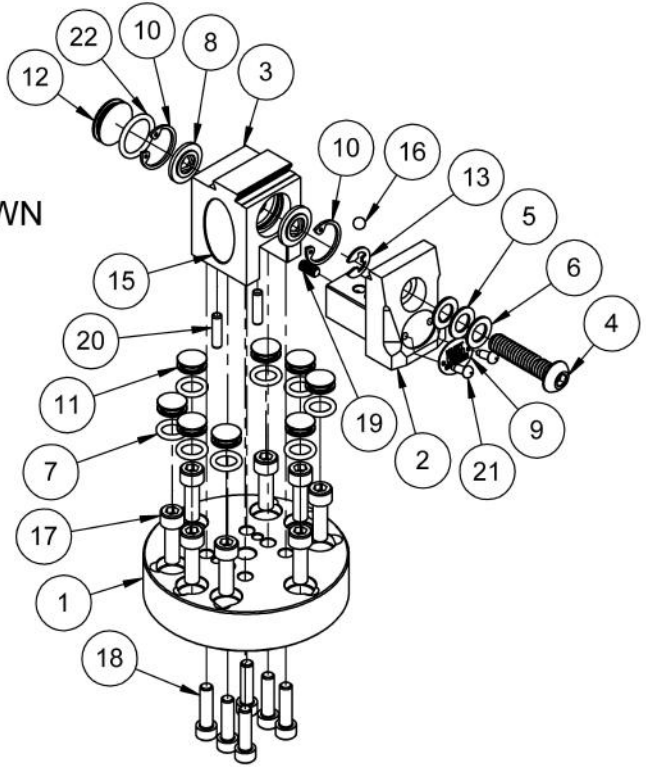

Maintenance Schedule

It is very important to perform regular maintenance on your Kurt vise to ensure proper operation. Improper maintenance will result in poor vise performance and may void your warranty.

Daily/ Weekly

1. Remove chips from surface of vise.
2. Visually inspect for damage and cleanliness.
3. Air-dry and apply rust inhibiting oil to the machined surface of the vise.

Monthly

1. Loosen the set screw in the movable jaw.
2. Open the vise until the screw releases from the stationary jaw.
3. Clean and grease the screw and threaded portion of the stationary jaw.

3-6 Months

1. Open the vise to the maximum opening.
2. Remove the main screw (#4 in Fig.7).
3. Remove and inspect the thrust bearing and washers (#5 & #6 in Fig.7).
4. Remove the protective plug (#12 in Fig.7) from the back.
5. Remove any chips, clean and apply a light coat of machine oil to the machined surface of the following item
 - a. Screw assembly
(clean exposed threads on the screw and base)
 - b. Bed of vise
 - c. Inside of the vise
6. Remove the ball from the movable jaw, then clean and oil the ball and the cavity it sits in.
7. Install the thrust bearing and washers.
8. Install main screw.
9. Your vise is now ready for use. Open and close your vise to check for proper operation. Center the part to be clamped in the vise and close. Your parts should be centered from side to side to insure proper clamping.

Troubleshooting Tips

If properly maintained, The Kurt DTR10 vise will operate trouble free for many years. In some cases, it will be necessary to troubleshoot. Use the information below to help in the process.

Problem: My vise turns hard.

Tip: As a new vise the brush seal could be stiff. Allow for break in of vise.

Tip: As a used vise, it could be filled with chips and threads could be jammed. Properly clean and grease vise.

Problem: My vise will not turn in either direction.

Tip: The vise is jammed with debris. Disassemble and clean as needed.

Problem: My vise won't hold tolerance.

Tip: You may be experiencing jaw lift from clamping too high or on one side of the jaw. Lower the part in the vise jaw and clamp more material.

Problem: My vise is stiff when clamping on a part or is difficult to back off a part.

Tip: The vise's thrust bearing pack may need to be replaced.

Problem: My vise is not clamping at a high clamping force.

Tip: The vise's thrust bearing pack may need to be replaced.

LIFETIME WARRANTY IRON CLAD™

All Kurt Manufacturing Company industrial workholding products and parts with the exceptions noted below, are warranted against defects in material and workmanship for the life of the product or part. (The life of the product is defined as that point in time when such item no longer functions due to normal wear and tear.) Failure to properly maintain and/or properly operate the product or part that has been worn out, abused heated ground or otherwise altered, used for a purpose other than that for which it was intended, or used in a manner inconsistent with any instructions regarding its use. The sole obligation of Kurt Manufacturing Company, Inc. (Kurt) and the purchaser's SOLE AND EXCLUSIVE REMEDY hereunder, shall be limited to the replacement or repair of any Kurt product or part (by an authorized Kurt technician) which are returned to Kurt Manufacturing Company's place of business, transportation, shipping and postal charges prepaid, and there determined by Kurt Manufacturing Company to be covered by the warranty contained herein.

THE LIMITED WARRANTY DESCRIBED HEREIN IS MADE EXPRESSLY IN LIEU OF ANY OTHER EXPRESSED OR IMPLIED WARRANTIES, INCLUDING ANY IMPLIED WARRANTY OF MERCHANTABILITY OR FITNESS FOR A PARTICULAR PURPOSE. KURT MANUFACTURING COMPANY IS NOT RESPONSIBLE FOR THE IMPROPER USE OF ITS PRODUCTS. KURT SHALL NOT BE LIABLE FOR ANY DIRECT, INDIRECT, INCIDENTAL SPECIAL OR CONSEQUENTIAL DAMAGES, INCLUDING BUT NOT LIMITED TO, LOSS OF USE, REVENUE OR PROFIT.

KURT ASSUMES NO LIABILITY FOR, AND MAKES NO WARRANTY REGARDING ANY PURCHASE ITEMS WHERE THE MANUFACTURER OF SUCH ITEM EXTENDS A SEPARATE WARRANTY.



KURT WORKHOLDING

**Thank you for your
purchase! If you
have any feedback
or questions please
contact us at.**

kurtworkholding.com |

Kurt Industrial Products//A Division Of Kurt Manufacturing

9445 East River Road NW | Mpls, MN 55433 | workholding@kurt.com

Phone 763-574-8309 | Toll Free 877-226-7823

Fax 763-574-8318 | Toll Free Fax 877-226-7823

Manual Revision:
3.31.2022