



KURT WORKHOLDING

PF420C

PF420D

PF420S

Operating Instruction Manual



ENGLISH

TABLE OF CONTENTS

Introduction	3
Operating Instructions	3
Installation & Mounting Guide	4-5
PF420 Parts List	6
PF420 Mechanical Drawing	7
Standard Jaw Options	8
Centerline Adjustment & Lash Removal	9
Jaw Removal	10
Machining the Carvable Jaws	11
Maintenance Schedule	12
Maintenance Log/Notes	13
Iron Clad Warranty.....	14
Thank You!	15

WISE DATA

Use this to fill out information about your vise for quick reference.

Purchase Date: _____ - _____ - _____

Purchase Order: _____

Purchased From: _____

Delivery Date: _____

Serial No.: _____

NOTE: MAKE SURE TO REGISTER YOUR WARRANTY ONLINE AT KURTWORKHOLDING.COM

INTRODUCTION

Thank you for purchasing a Kurt Precision Force vise. The PF Series of vises are top of the line workholding options for today's rapidly growing 5-Axis market. Backed by a lifetime warranty against workmanship and material defects, these vises will perform at the highest levels of precision and reliability for years to come, when used and maintained properly.

Kurt Anglock maintains it's time tested design, which gives you the part pull down that you need when machining high end parts. Other features Include:

- Gibbed jaws for maximum clamping repeatability
- Multiple interchangeable jaw options
 - Carvable (PF420C)
 - Dovetail (PF420D)
 - Serrated (PF420S)
- Easily adjustable center line
- Fast and effortless lash removal system
- Double ended screw for flexible vise operation

PF Vise Clamp Force

10 ft. lbs.	720 force lbs.
20 ft. lbs.	1,520 force lbs
30 ft. lbs.	2,250 force lbs
40 ft. lbs.	3,050 force lbs
45 ft. lbs.	3,375 force lbs

OPERATING INSTRUCTIONS

For proper vise operation insert the handle onto the hex of the vise. This handle, combined with the correct amount of torque will provide you with all the clamping force you will need to machine your parts. DO NOT use any other type of pressure to open or close your vise.

The uses of handle extensions, air impact wrenches, breaker bars, or hammer strikes are not recommended and will void the warranty if used. This will also cause damage to the central holding block and screw threads. If you need more clamping force you may require a larger vise.

To properly clamp a part in your Kurt vise you should place the part in the center of the jaws. Clamping only on one side can result in loss of accuracy. If one-sided clamping is necessary you MUST use a dummy part on the other side.

INSTALLATION & MOUNTING

All of the vises in the PF Series can be mounted with 1/2 inch SHCS using the counter-bored through holes in the center of the rails of the vise.

Additional hole locations are shown below.

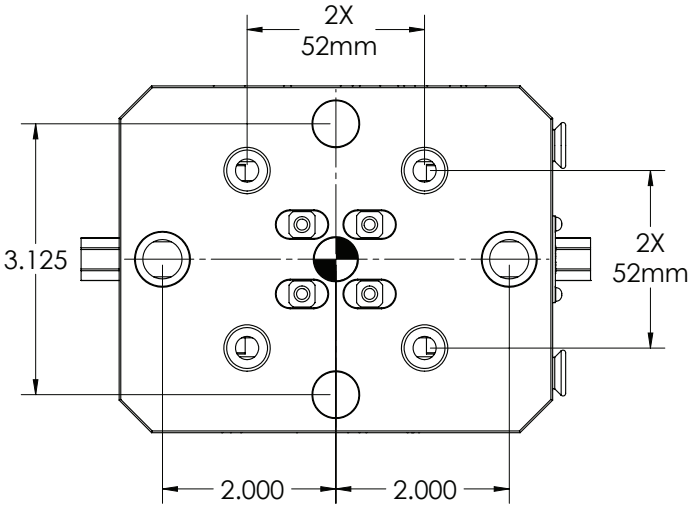

2X DRILLED & C'BORED
FOR 1/2" SHCS

Ø0.500 ∇ 0.500

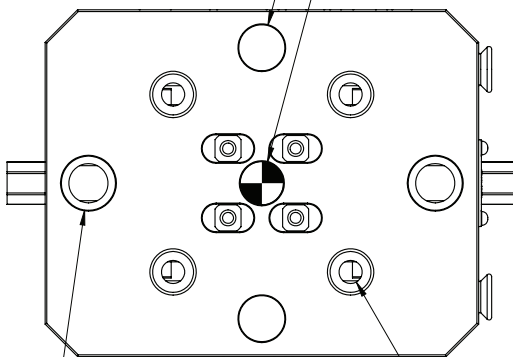

JAW ASSEMBLY

When you receive your new PF Series vise, you will notice that the jaws do not come attached. To install the vise jaws, follow the steps given below.

1. Place both movable jaws on the rails of the vise, and slide the movable jaws over the beaks of the nuts.
2. Set the rear covers into their slots in the back of the movable jaws, then use the button head screws to anchor the rear covers to the movable jaws.
3. Finish Securing the movable jaws by installing the spring plungers into the rear covers. Tighten the spring plungers until they are snug, then loosen them by 1/8 to 1/4 turn.

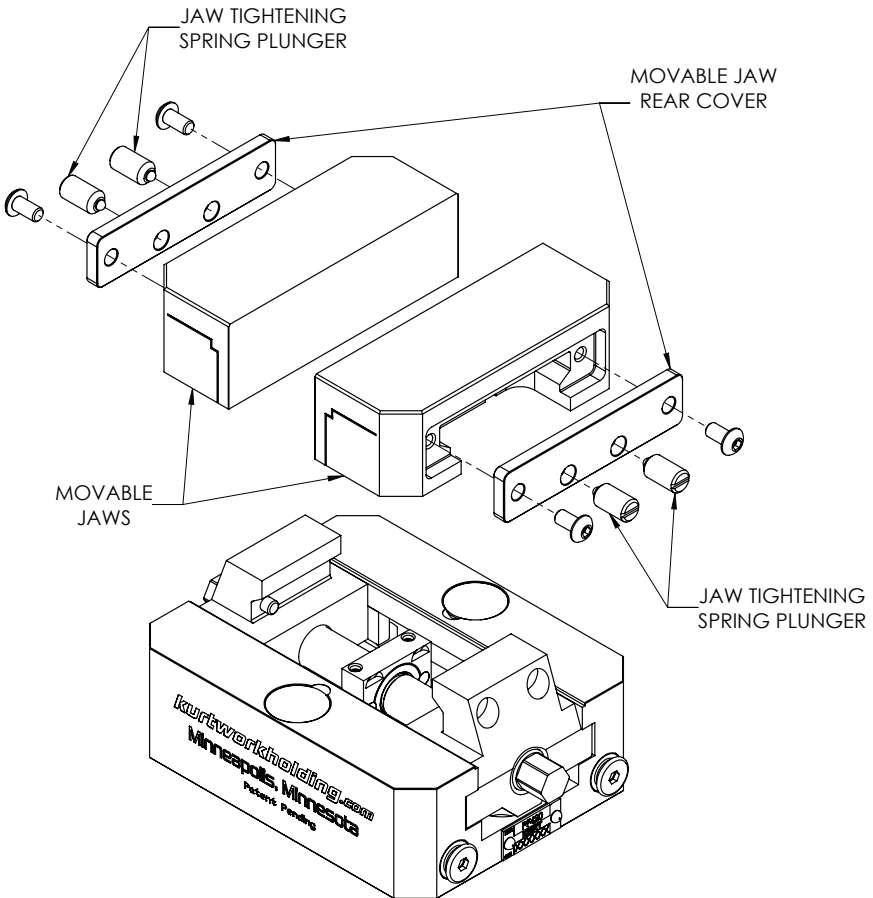

PF420 PARTS LIST

ITEM#	PART #	DESCRIPTION	QTY.
1	PF420-1	Body	1
2	PF420-2*	Movable Jaw	2
3	PF420-3R	Nut 9/16-18 Right Hand Thread	1
4	PF420-3L	Nut 9/16-18 Left Hand Thread	1
5	PF250-5	Screw	1
6	PF420-53	Rear Cover	2
7	PF420-102	Model/Serial Number Tag	1
8	PF420-169	Compression Spring	4
9	DLU4-96	O-Ring #16	2
10	PF250-195	Heavy Duty Square Nut	4
11	PF250-196	Set Screw w/Nyloc Modified	2
12	PF250-212	Central Holding Block	1
15	PF250-272	Thrust Washer Collar	1
17	PF250-311	Straight Wire Spring	2
18	PF250-364L	Locking Pin Left Hand	1
19	PF250-364R	Locking Pin Right Hand	1
20	PF420-366	Spring Plunger	4
21	3600V-191	Protective Cap	2
22	00-119	SHCS 8-32 X 0.562 LG	4
23	01-1853	Half Dog Set Screw	2
24	03-0021	SBHCS 10-32 X 0.375 LG	4
25	04-0028	Dowel Pin	2
26	07-0230	U-Type Drive Screw	2
27	PF420-16	Pad Guide	4
28	PF420-367	Pull Stud for Lifting Vise	2
29	PF420-10-SA	P420-10-SA Handle Assembly	1
*Note: PF420C Carvable Jaw - PF420-2C PF420D Dovetail Jaw - PF420-2D PF420S Serrated Jaw - PF420-2S			

PF420 MECHANICAL DRAWING

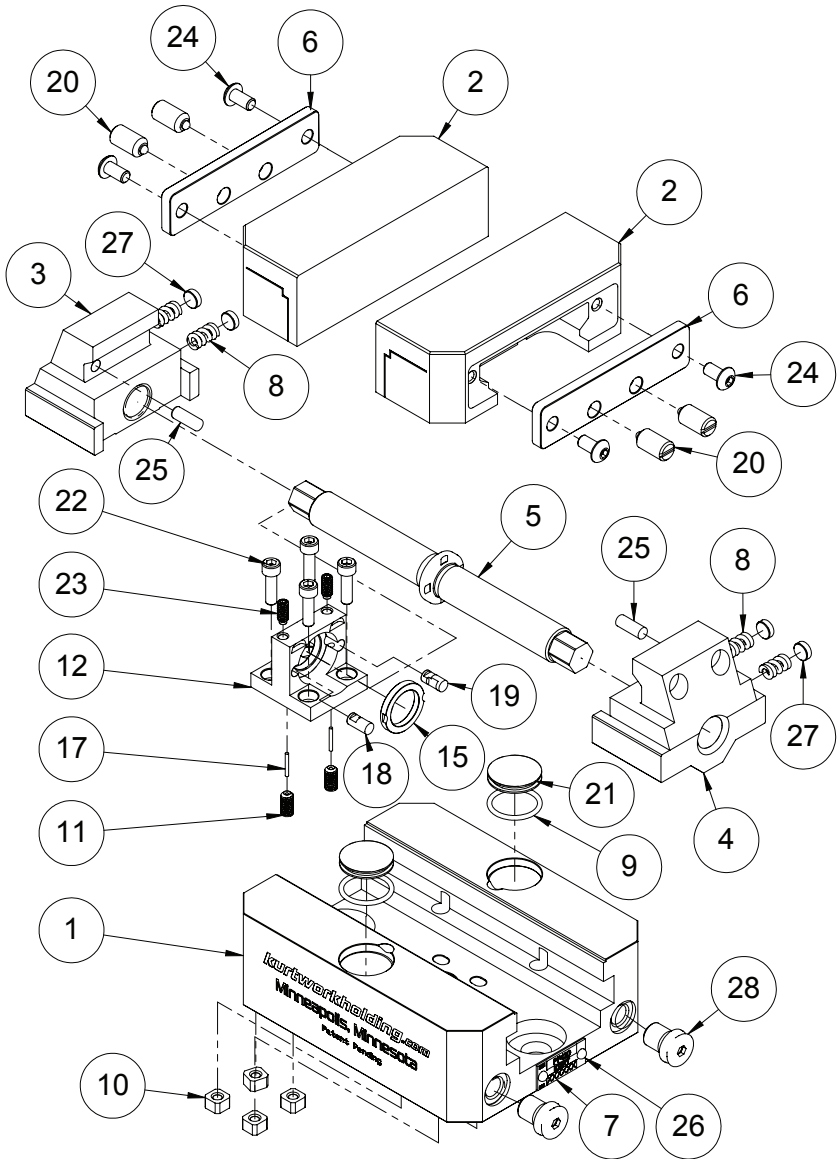

STANDARD JAW OPTIONS

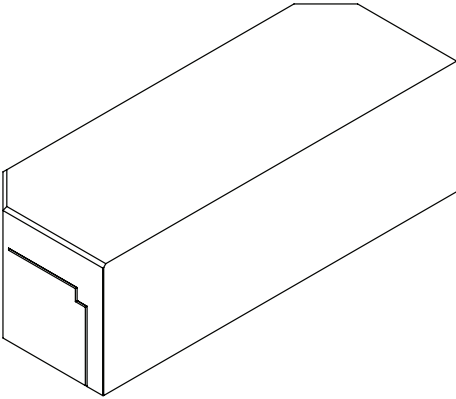

PF Series Carvable Jaws
Part Number: PF420-2C

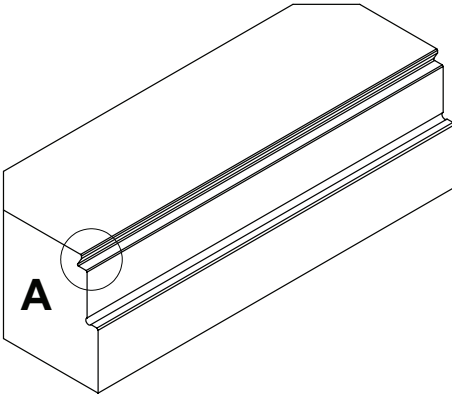

PF Series Dovetail Jaws
Part Number: PF420-2D

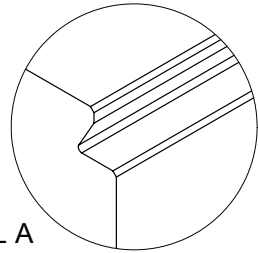

DETAIL A

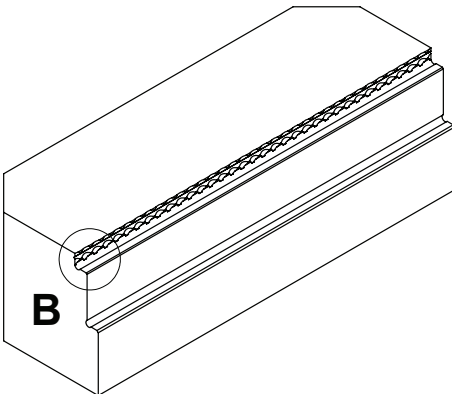

PF Series Serrated Jaws
Part Number: PF420-2S

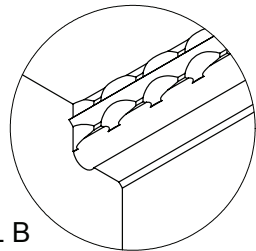

DETAIL B

CENTERLINE ADJUSTMENT

The PF Series of vises are designed for quick and easy adjustment of the vise centerline.

1. Loosen the four centerline adjustment bolts using a 9/64 hex wrench
2. Adjust the centerline by sliding the nut and screw assembly within the body of the vise. A mallet may be required to gently tap the ends of the screw in the direction of the desired adjustment.
3. When the centerline is in the desired position, re-tighten the four centerline adjustment bolts.

LASH REMOVAL

Along with an easily adjustable centerline, the PF vises also have an extremely simple to use lash removal system.

1. Loosen the two lash release bolts on the top surface of the central holding block, using a 5/64 hex wrench.
2. Tap the top of the central holding block with your finger.
3. Re-tighten the lash release bolts.

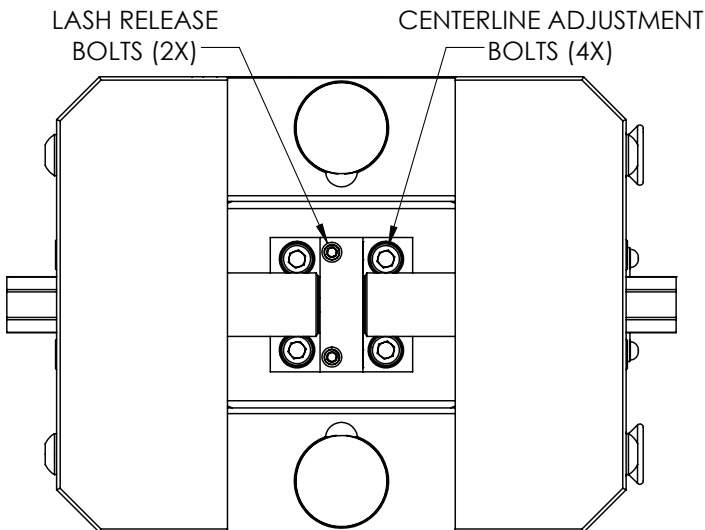

JAW REMOVAL

The Jaws on the PF 420 are easily removed. The following steps will help you remove them for replacement or maintenance purposes.

1. Loosen the spring plungers with a flat head screwdriver, to remove any spring forces that may be pushing against the rear cover plate.
2. Loosen and remove the two button head screws that attach the rear cover plate to the movable jaw, using a 1/8 hex wrench.
3. Slide the free jaw forward on the bed of the vise until it clears the beak of the nut. Then lift the freed jaw off of the vise.
4. Repeat the above process for the second jaw.

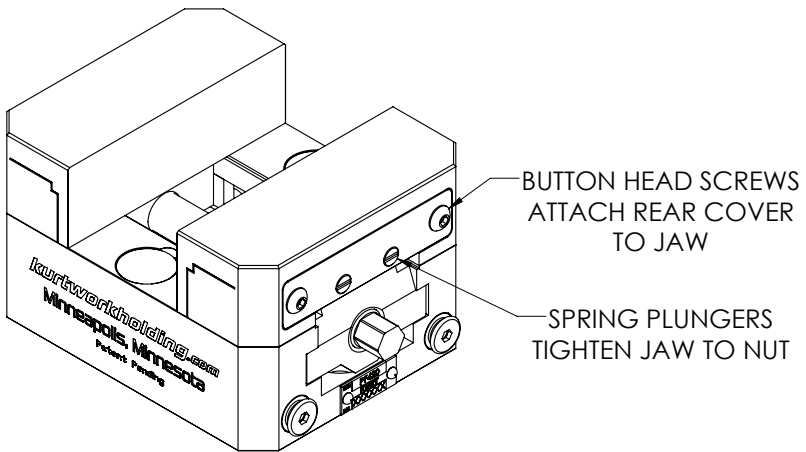

MAINTENANCE SCHEDULE

It is very important to perform regular maintenance on your Kurt vise to assure proper operation. Improper maintenance will result in poor vise performance and may void your warranty.

Daily/Weekly

1. Remove chips from surface of vise.
2. Visually inspect for chips, seals for damage and cleanliness.
3. Visually inspect for chip entrapments and remove when necessary.
4. Air-dry and apply rust inhibiting oil to the machined surface of the vise.

Monthly

1. Open the vise to the maximum opening.
2. Remove the movable jaws using the procedure on page 10.
3. Turn the movable jaw over and clean the inside cavity.
4. Remove any chips, clean and apply a light coat of machine oil to the machined surface of the following item
 - a. Nut and Screw assembly (clean exposed threads on the screw)
 - b. Bed of vise (top of "rails")
 - c. Inside of the vise between the center ways.
5. Your vise is now ready for use. Open and close your vise to check for proper operation. Center the part to be clamped in the vise and close. Your parts should be centered from side to side to insure proper clamping. (See Fig.1 below)

LIFETIME WARRANTY IRON CLAD™

All Kurt Manufacturing Company industrial workholding products and parts with the exceptions noted below, are warranted against defects in material and workmanship for the life of the product or part. (The life of the product is defined as that point in time when such item no longer functions due to normal wear and tear.) Failure to properly maintain and/or properly operate the product or part that has been worn out, abused, heated, ground or otherwise altered, used for a purpose other than that for which it was intended, or used in a manner inconsistent with any instructions regarding its use. The sole obligation of Kurt Manufacturing Company, Inc. (Kurt) and the purchaser's SOLE AND EXCLUSIVE REMEDY hereunder, shall be limited to the replacement or repair of any Kurt product or part (by an authorized Kurt technician) which are returned to Kurt Manufacturing Company's place of business or any authorized service center, transportation, shipping and postal charges prepaid, and there determined by Kurt Manufacturing Company to be covered by the warranty contained herein.

THE LIMITED WARRANTY DESCRIBED HEREIN IS MADE EXPRESSLY IN LIEU OF ANY OTHER EXPRESSED OR IMPLIED WARRANTIES, INCLUDING ANY IMPLIED WARRANTY OF MERCHANTABILITY OR FITNESS FOR A PARTICULAR PURPOSE. KURT MANUFACTURING COMPANY IS NOT RESPONSIBLE FOR THE IMPROPER USE OF ITS PRODUCTS. KURT SHALL NOT BE LIABLE FOR ANY DIRECT, INDIRECT, INCIDENTAL SPECIAL OR CONSEQUENTIAL DAMAGES, INCLUDING BUT NOT LIMITED TO, LOSS OF USE, REVENUE OR PROFIT.

KURT ASSUMES NO LIABILITY FOR, AND MAKES NO WARRANTY REGARDING ANY PURCHASE ITEMS WHERE THE MANUFACTURER OF SUCH ITEM EXTENDS A SEPARATE WARRANTY.



KURT WORKHOLDING

**Thank you for your
purchase! If you
have any feedback
or questions please
contact us at.**

kurtworkholding.com |

Kurt Industrial Products//A Division Of Kurt Manufacturing

9445 East River Road NW | Mpls, MN 55433 | workholding@kurt.com

Phone 763-574-8309 | Toll Free 877-226-7823

Fax 763-574-8318 | Toll Free Fax 877-226-7823

Manual Revision:
2020-05-12