



STANDARD (3600) AND SHORT (3620)

VERSATILE LOCK® VISES

PATENTED

Models:
Manual
Hydraulic
Air



3600V



3600H - Standard Hydraulic

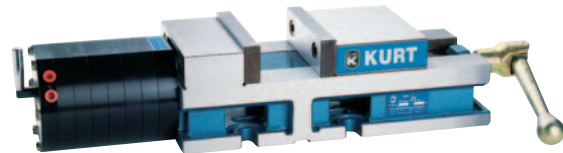

3600A - Standard Air

The Versatile Lock vise is the industry's ultimate single station CNC vise. It offers ultra-precision function through these important design features: The original, time proven Kurt AngLock design prevents parts from lifting upward under heavy clamping loads. The "pull-type" jaw clamping reduces jaw stationary deflection by at least 80%. The one piece vise body and stationary jaw provide greater strength while reducing weight.

Features:

- Can be mounted upright or on either side.
- Matched stationary jaw to keyway including the body height ± 0.001 ".
- 0.0005" clamping repeatability.
- Footprint on the short version is 13". Ideal for the smallest machines.
- Hydraulic option is available as a complete package including the intensifier (specify foot or hand actuation). (See Page 60). Each vise must have it's own intensifier.
- All air and hydraulic units feature a 1/4" vise stroke.
- Air vise has a precise and repeatable "gentle touch" for delicate parts.
- Some models available in metric.
- Optional internal hex available for 3600V only. (3600V-INT).



The 3600V shown mounted "back to back". Makes a fast, easy and economical vise tombstone. Bases can be tailored for most HMC's.

VERSATILE LOCK® VISES

PATENTED

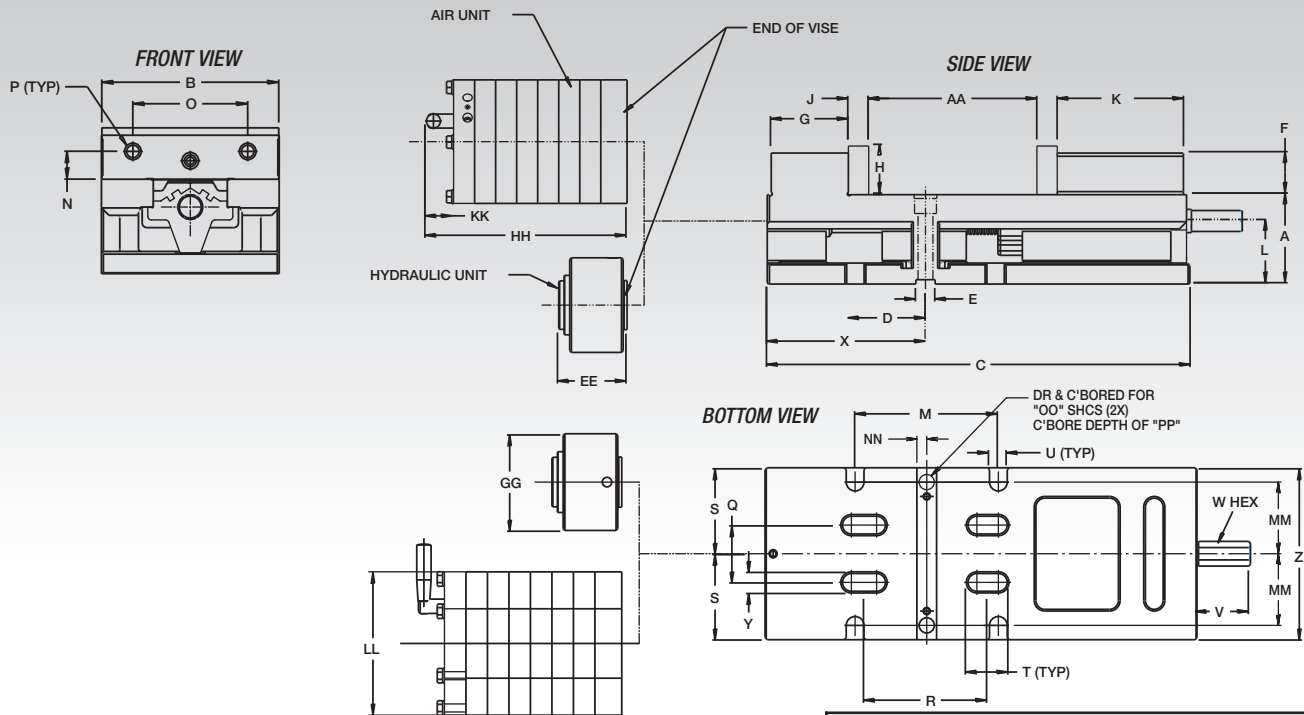

JAW POSITIONS

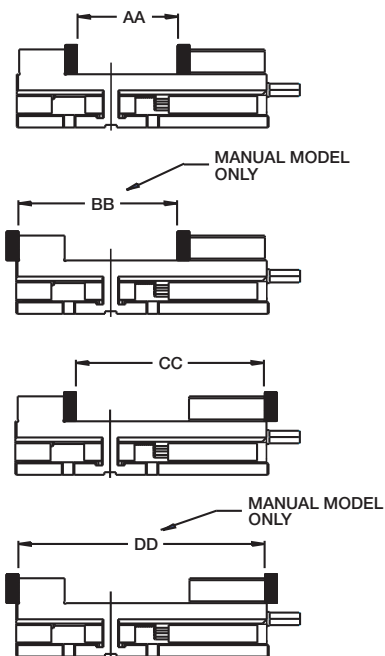

VISE CLAMPING FORCE-LBS.		
Manual Torque Ft.-Lbs.	Manual	
	3600V	3620V
10	653	653
20	1743	1743
30	2234	2234
40	3015	3015
50	3833	3833
60	4438	4438
70	5528	5528
80	6356	6356

VISE CLAMPING FORCE-LBS.		
Hydraulic PSI	Hydraulic	
	3600H	3620H
400	1575	1575
800	3150	3150
1200	4725	4725
1600	6300	6300
2000	7875	7875
2400	9450	9450
2800	11025	11025
3200	12600	12600
Hydraulic Displacement cu. In.	1.18	1.18

VISE CLAMPING FORCE-LBS.		
Air PSI	Air	
	3600A	3620A
10	320	320
20	840	840
30	1280	1280
40	1780	1780
50	2200	2200
60	2720	2720
70	3240	3240
80	3800	3800
90	4380	4380
100	5000	5000

Repair Kits

MODEL	REPAIR KIT
3600V	*3600V-KIT

*= Same as Metric Vise

	DIMENSIONAL DATA					
	Manual		Hydraulic		Air	
	3600V	3620V	3600H	3620H	3600A	3620A
A	3.187	3.187	3.187	3.187	3.187	3.187
B	6.000	6.000	6.000	6.000	6.000	6.000
C	15.060	12.940	15.060	12.940	15.060	12.940
D	2.750	2.750	2.750	2.750	2.750	2.750
E	0.688	0.688	0.688	0.688	0.688	0.688
F	1.485	1.485	1.485	1.485	1.485	1.485
G	2.750	2.750	2.750	2.750	2.750	2.750
H	1.735	1.735	1.735	1.735	1.735	1.735
J	0.725	0.725	0.725	0.725	0.725	0.725
K	4.500	4.500	4.500	4.500	4.500	4.500
L	2.250	2.250	2.250	2.250	2.250	2.250
M	5.000	5.000	5.000	5.000	5.000	5.000
N	0.937	0.937	0.937	0.937	0.937	0.937
O	3.875	3.875	3.875	3.875	3.875	3.875
P	1/2-13	1/2-13	1/2-13	1/2-13	1/2-13	1/2-13
Q	2.000	2.000	2.000	2.000	2.000	2.000
R	4.250	4.250	4.250	4.250	4.250	4.250
S	3.000	3.000	3.000	3.000	3.000	3.000
T	1.380	1.380	1.380	1.380	1.380	1.380
U	0.630	0.630	0.630	0.630	0.630	0.630
V	1.940	1.940	1.940	1.940	1.940	1.940
W	3/4	3/4	3/4	3/4	3/4	3/4
X	5.640	5.640	5.640	5.640	5.640	5.640
Y	0.630	0.630	0.630	0.630	0.630	0.630
Z	6.000	6.000	6.000	6.000	6.000	6.000
AA	6.000	4.000	6.000	4.000	6.000	4.000
BB	9.500	7.500	-	-	-	-
CC	11.250	9.250	11.250	9.250	11.250	9.250
DD	14.750	12.750	-	-	-	-
EE	-	-	2.410	2.410	-	-
GG	-	-	3.375	3.375	-	-
HH	-	-	-	-	7.220	7.220
KK	-	-	-	-	1.030	1.030
LL	-	-	-	-	5.000	5.000
MM	2.500	2.500	2.500	2.500	2.500	2.500
NN	0.344	0.344	0.344	0.344	0.344	0.344
OO	1/2	1/2	1/2	1/2	1/2	1/2
PP	0.671	0.671	0.671	0.671	0.671	0.671
Est Ship Wt. Lbs.	69	64	74	69	75	70



Models:
Manual
Hydraulic
Air

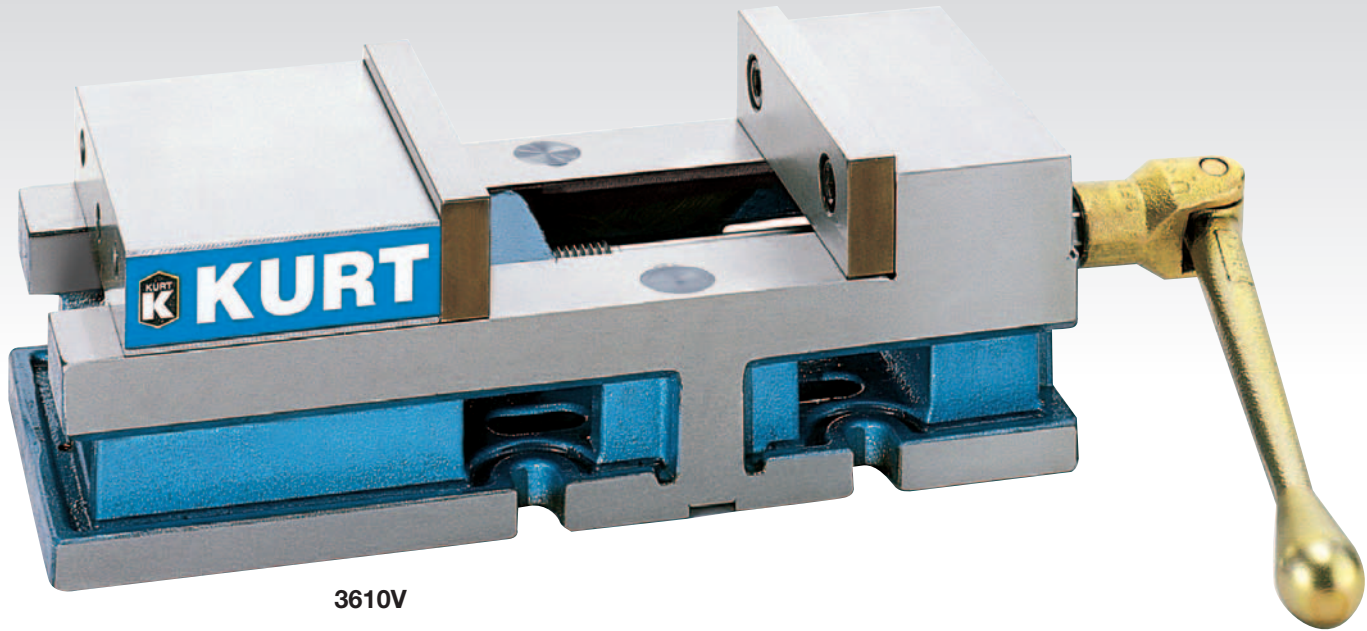

3610V

Use the Versatile Lock in this configuration for the added benefit of easier part programming in “Y axis” positive direction. It also reduces the “reach-over” distance making part loading safer and easier for the operator.

Features:

- Can be mounted upright or on either side.
- Matched stationary jaw to the keyway including the body height ± 0.001 ".
- 0.0005" clamping repeatability.
- Footprint on the short version is 13". Ideal for the smallest machines.
- Hydraulic option is available as a complete package including the intensifier (specify foot or hand actuation). Each vise must have it's own intensifier.
- All air and hydraulic units feature a 1/4" vise stroke.
- Air vise has a precise and repeatable "gentle touch" for delicate parts.
- Some models available in metric.

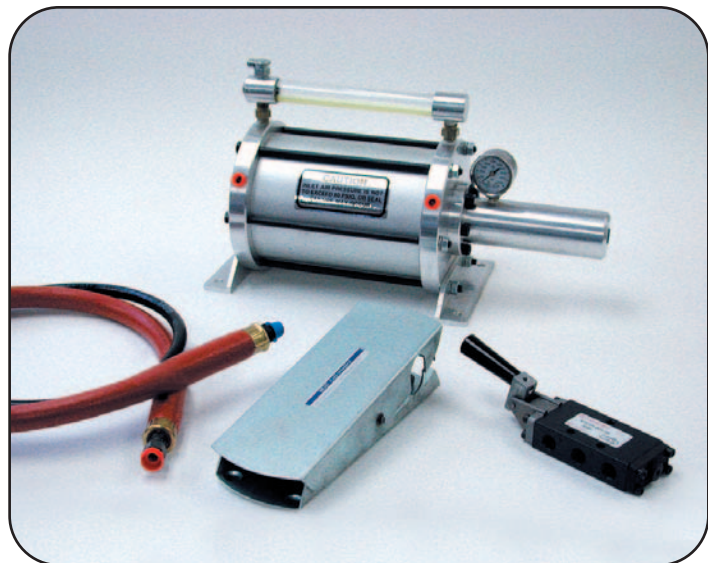

Intensifier, p.60

- APD50-112-Hand
- APD50-112-Foot

VERSATILE LOCK® VISES

PATENTED

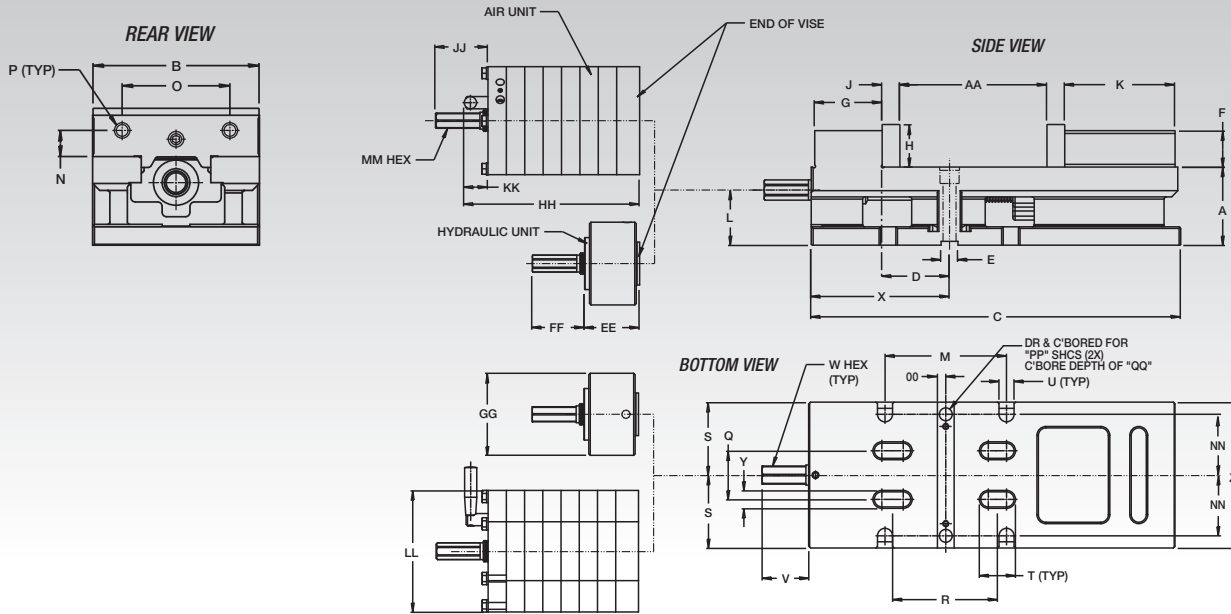

JAW POSITIONS

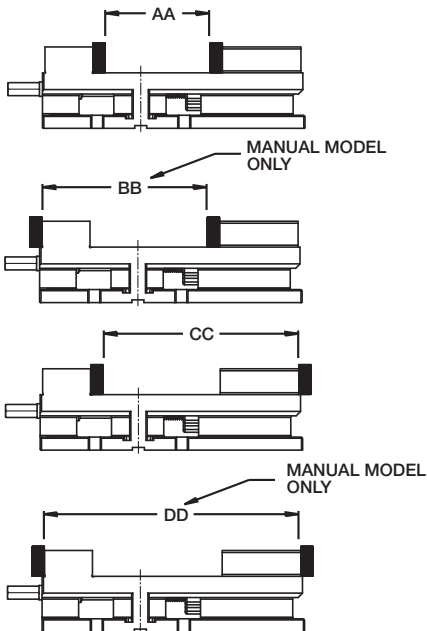

VISE CLAMPING FORCE-LBS.		
Manual torque Ft.-Lbs.	Manual	
	3610V	3630V
10	653	653
20	1743	1743
30	2234	2234
40	3015	3015
50	3833	3833
60	4438	4438
70	5528	5528
80	6356	6356

VISE CLAMPING FORCE-LBS.		
Hydraulic PSI	Hydraulic	
	3610H	3630H
400	1575	1575
800	3150	3150
1200	4725	4725
1600	6300	6300
2000	7875	7875
2400	9450	9450
2800	11025	11025
3200	12600	12600
Hydraulic Displacement cu. In	1.18	1.18

VISE CLAMPING FORCE-LBS.		
Air PSI	Air	
	3610A	3630A
10	320	320
20	840	840
30	1280	1280
40	1780	1780
50	2200	2200
60	2720	2720
70	3240	3240
80	3800	3800
90	4380	4380
100	5000	5000

	DIMENSIONAL DATA					
	Manual		Hydraulic		Air	
	3610V	3630V	3610H	3630H	3610A	3630A
A	3.187	3.187	3.187	3.187	3.187	3.187
B	6.000	6.000	6.000	6.000	6.000	6.000
C	15.060	12.940	15.060	12.940	15.060	12.940
D	2.750	2.750	2.750	2.750	2.750	2.750
E	0.688	0.688	0.688	0.688	0.688	0.688
F	1.485	1.485	1.485	1.485	1.485	1.485
G	2.750	2.750	2.750	2.750	2.750	2.750
H	1.735	1.735	1.735	1.735	1.735	1.735
J	0.725	0.725	0.725	0.725	0.725	0.725
K	4.500	4.500	4.500	4.500	4.500	4.500
L	2.250	2.250	2.250	2.250	2.250	2.250
M	5.000	5.000	5.000	5.000	5.000	5.000
N	0.937	0.937	0.937	0.937	0.937	0.937
O	3.875	3.875	3.875	3.875	3.875	3.875
P	1/2-13	1/2-13	1/2-13	1/2-13	1/2-13	1/2-13
Q	2.000	2.000	2.000	2.000	2.000	2.000
R	4.250	4.250	4.250	4.250	4.250	4.250
S	3.000	3.000	3.000	3.000	3.000	3.000
T	1.380	1.380	1.380	1.380	1.380	1.380
U	0.630	0.630	0.630	0.630	0.630	0.630
V	1.940	1.940	1.940	1.940	1.940	1.940
W	3/4	3/4	3/4	3/4	3/4	3/4
X	5.640	5.640	5.640	5.640	5.640	5.640
Y	0.630	0.630	0.630	0.630	0.630	0.630
Z	6.000	6.000	6.000	6.000	6.000	6.000
AA	6.000	4.000	6.000	4.000	6.000	4.000
BB	9.500	7.500	-	-	-	-
CC	11.250	9.250	11.250	9.250	11.250	9.250
DD	14.750	12.750	-	-	-	-
EE	-	-	2.410	2.410	-	-
FF	-	-	1.940	1.940	-	-
GG	-	-	3.375	3.375	-	-
HH	-	-	-	-	7.220	7.220
JJ	-	-	-	-	2.100	2.100
KK	-	-	-	-	1.030	1.030
LL	-	-	-	-	5.000	5.000
MM	-	-	-	-	5/8	5/8
NN	2.500	2.500	2.500	2.500	2.500	2.500
OO	0.344	0.344	0.344	0.344	0.344	0.344
PP	1/2	1/2	1/2	1/2	1/2	1/2
QQ	0.671	0.671	0.671	0.671	0.671	0.671
Ship Wt. Lbs.	68	64	73	68	74	69