



MOVELOCK MODULAR SYSTEM

PATENTED



Hydraulic Movable Jaw MLH35



Manual Movable Jaw ML35

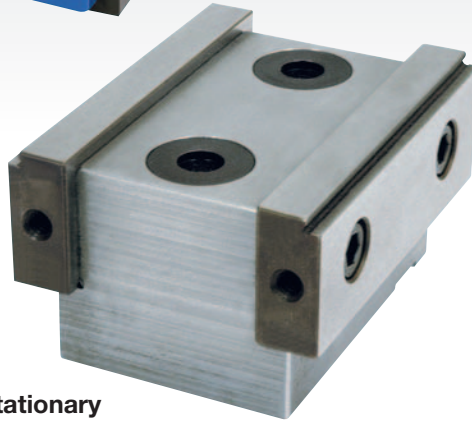

Stationary Jaw MLS351

Hyd. Pressure (PSI)	Clamping Force (LBS)
400	200
800	500
1200	850
1600	1200
2000	1550
2400	1850
2800	2150
3200	2500

Torque (FT LBS)	Clamping Force (LBS)
5	750
10	1550
15	2600
20	3550
25	4450
30	5400
35	6300
40	6900

This high precision two-piece vise is the first of its type to utilize the famous Kurt Anglock concept to prevent jaw lift during clamping. As power is applied to the piston, it is driven forward to locate on an internal segment. While the lateral force is clamping the part, downward pressure is being applied to the movable jaw, which minimizes or prevents part lift. For every pound of clamping force on the jaw, there is a half pound of force exerted down on the movable jaw.

Features:

- Movable and stationary jaws sold separately.
- Movable jaws are available in either manual or hydraulic actuation.
- May be used as a single or double station vise, and can be mounted side by side.
- Can be configured into high density fixturing.
- Features a 5/16" stroke.
- Mounts on a 2" x 2" grid system, T-slot sub-bases with a 2" pitch, standard sub-plates and machine tables and SeraLock system.
- Clamps large workpieces - jaw opening limited only by the work envelope.
- Light weight.
- Small footprint - 3.500" jaw width.

Special jaw plates and workstops are available. Contact the factory for pricing and availability.

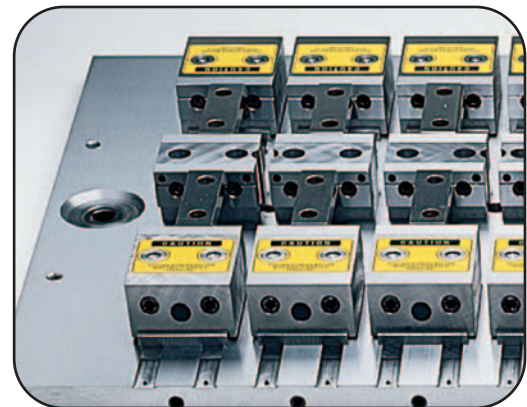

MOVELOCK MODULAR SYSTEM

PATENTED

Stationary Jaw MLS351 Serrated Stationary Jaw SMLS351

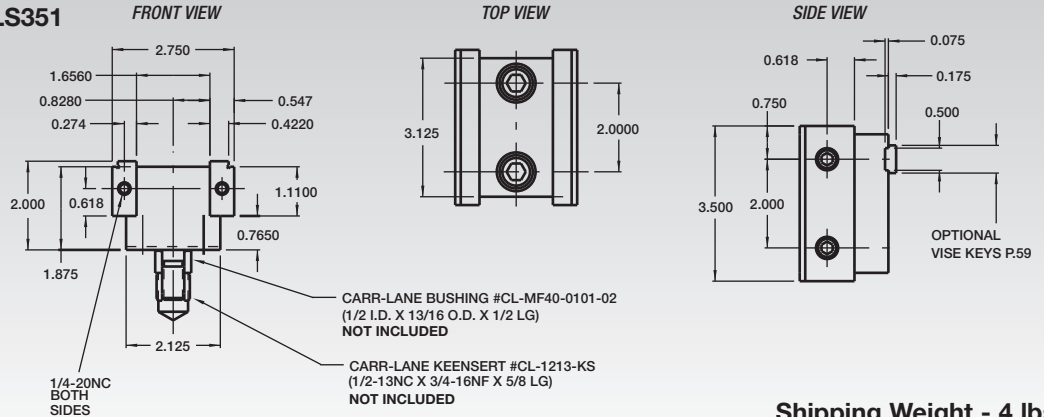
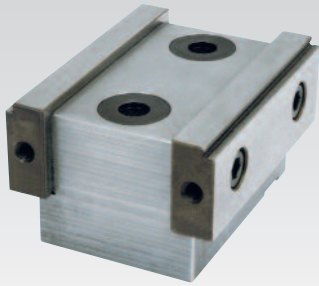

Shipping Weight - 4 lbs.

Manual Movable Jaw ML35 Serrated Manual Movable Jaw SML35

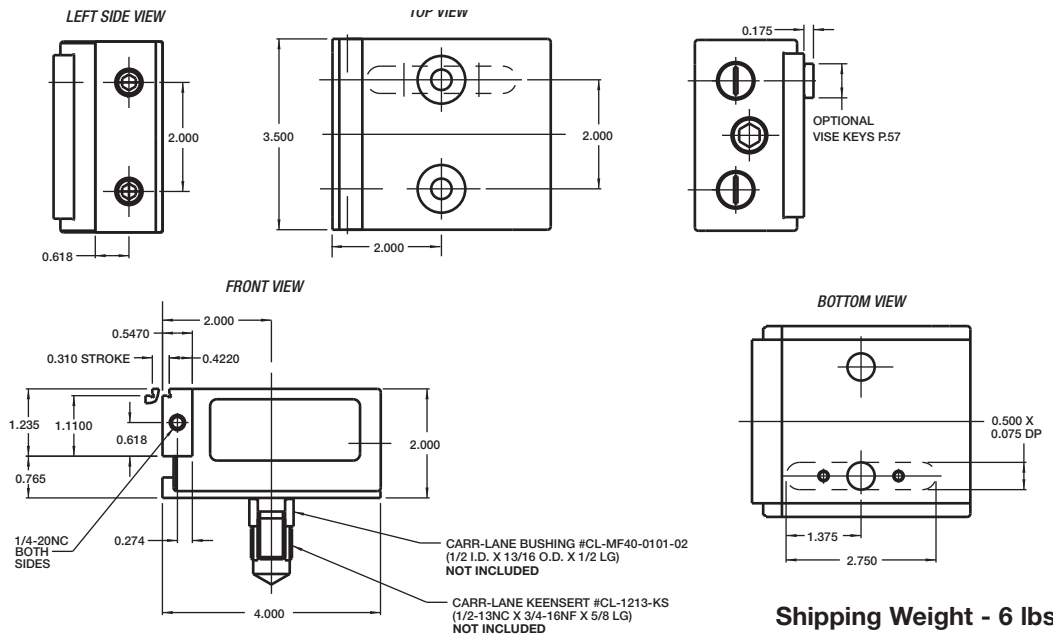

Shipping Weight - 6 lbs.

Hydraulic Movable Jaw MLH35 Serrated Hydraulic Movable Jaw SMLH35

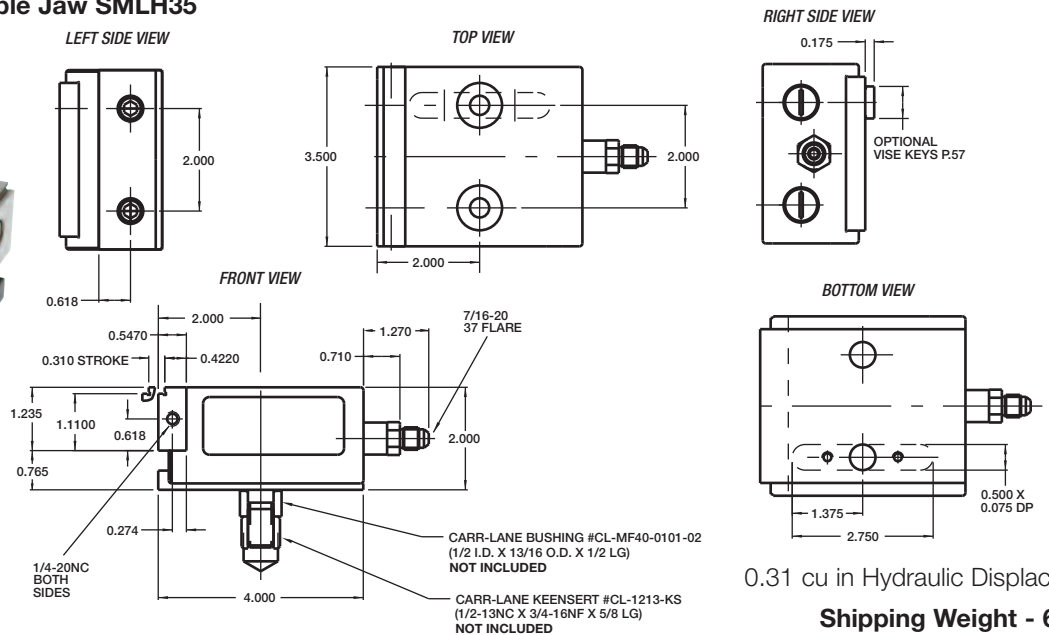

0.31 cu in Hydraulic Displacement

Shipping Weight - 6 lbs.