

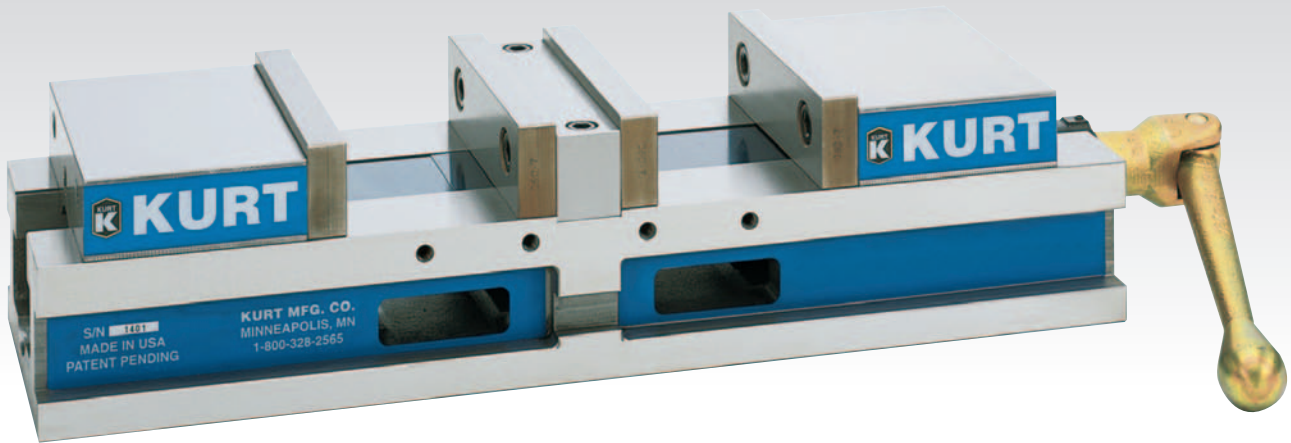

Models:
DL430®
DL800



OPTIONAL CONVERTIBLE KIT - JAW OPENING POSITIONS									
	A	B	C	D	E	F	G	H	Ship Wt. Lbs
DLC430 - KIT	8.094	2.094	11.370	8.640	5.731	2.641	9.188	3.188	2
DLC800 - KIT	16.000	12.000	23.000	17.000	19.000	13.000	18.000	14.000	20

The DL430 and DL800 DoubleLock vises offer cost saving productivity by maximizing the number of parts in the work envelope.

Features:

- Large Capacity
-DL430 4" wide x 3" opening each station.
-DL800 8" wide x 6" opening each station.
- Productivity – multiple part workholding for better spindle utilization, reduced tool change time, and reduced machine travel from part to part.
- Accuracy – repeatable clamping to 0.0002".
- Durability – 80,000-PSI ductile iron body and steel components provide strength, rigidity and long term accuracy while absorbing machining vibration.
- Self-adjusting holding block over the entire clamping range.
- Metric version available.
- Optional internal hex screw available.
- Pre-load is adjustable from 0.010" to 0.150".
- New holding back features the ability to clamp dissimilar sized parts and provides preloading ability in the front or back jaw.

OPTIONAL CONVERTIBLE KIT - JAW POSITIONS

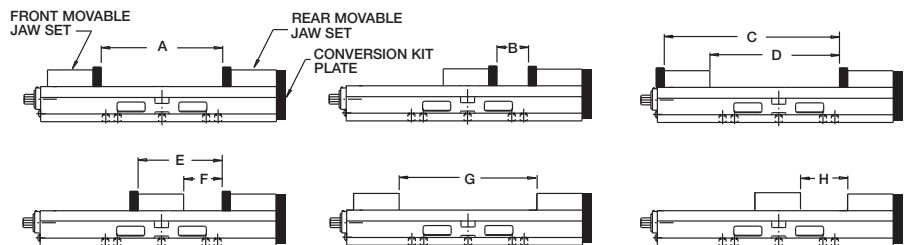

Shown with optional convertible kit.

Use your DoubleLock vise to it's full capacity with the DoubleLock convertible kit. The kit is available for the DL430 and DL800 vises.

Repair Kits

MODEL	REPAIR KIT	
DL430	*DL430-KIT	For All Serial Numbers
DL640	*DL640-KIT1	Vise Serial # 1000-3734
DL640	*DL640-KIT2	Vise Serial # 3735-4999
DL640	*DL640-KIT3	Vise Serial # 5001

* = Same as Metric Vise

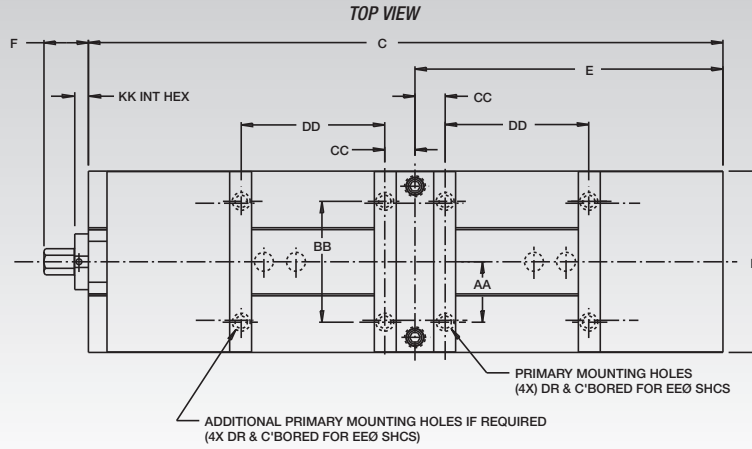

VISE CLAMPING FORCE-LBS		
Manual torque Ft.-lbs.	DL430	DL800
10	1046	-
20	1980	2023
30	2832	-
40	3740	3578
50	4523	-
60	-	5136
70	-	-
80	-	6883
100	-	8997

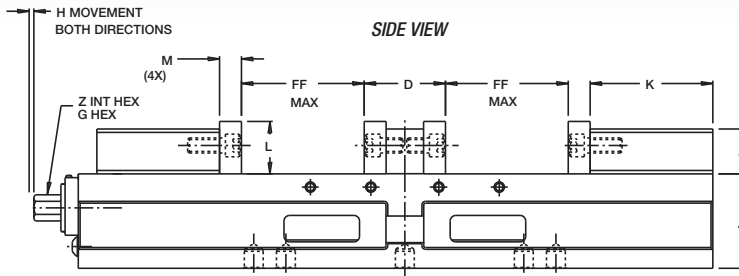

DIMENSIONAL DATA		
	DL430	DL800
A	2.375	3.750
B	4.000	8.060
C	16.125	30.000
D	2.094	4.000
E	7.750	15.000
F	1.340	4.250
G	5/8	7/8
H	0.120	0.190
J	1.115	1.965
K	3.090	6.000
L	1.235	2.200
M	0.547	1.075
N	0.687	1.220
O	2.500	4.750
P	3/8-16	5/8-11
Q	0.375	0.750
R	1.688	2.375
S	5/16-18	1/2-13
S1	-	5/8-11
T	3.000	7.000
T1	5.000	7.000
U	3.937	-
V	3.750	8.000
W	0.813	3.625
X	0.625	0.750
Y	0.6299	-
Z	7/16	-
AA	1.500	2.500
BB	3.000	5.000
CC	0.781	1.000
DD	3.625	7.500
EE	5/16	1/2
FF	3.000	6.000
GG	4.547	8.925
HH	6.637	13.075
JJ	8.184	16.000
KK	0.400	-
Ship wt	45	250

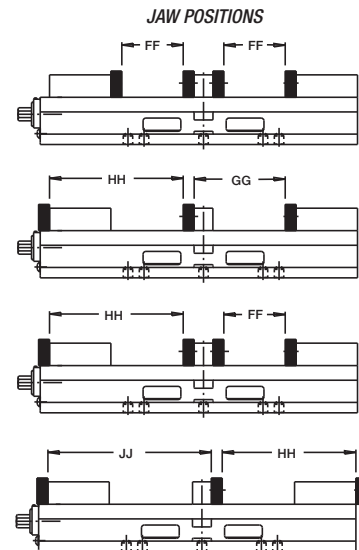
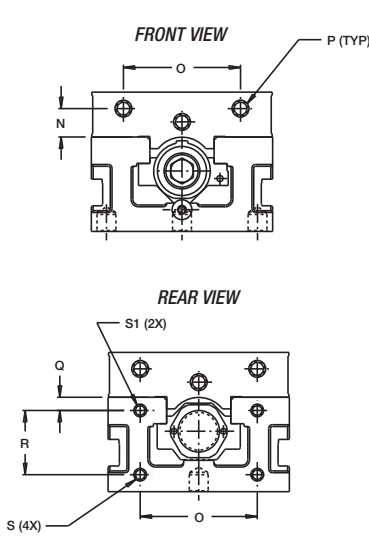
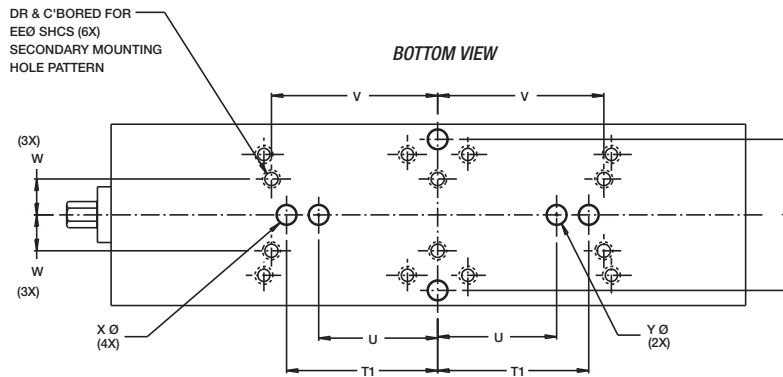



HYDRAULIC

DOUBLELOCK® VISES

Models:
DLH430
DLH800

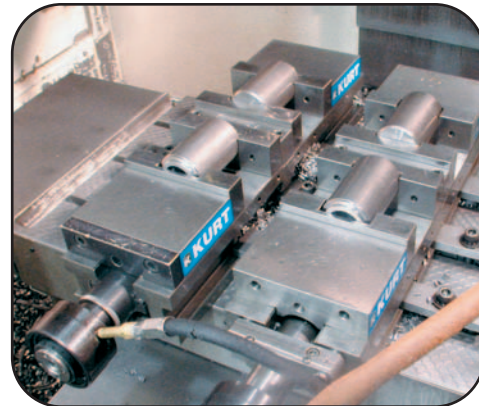
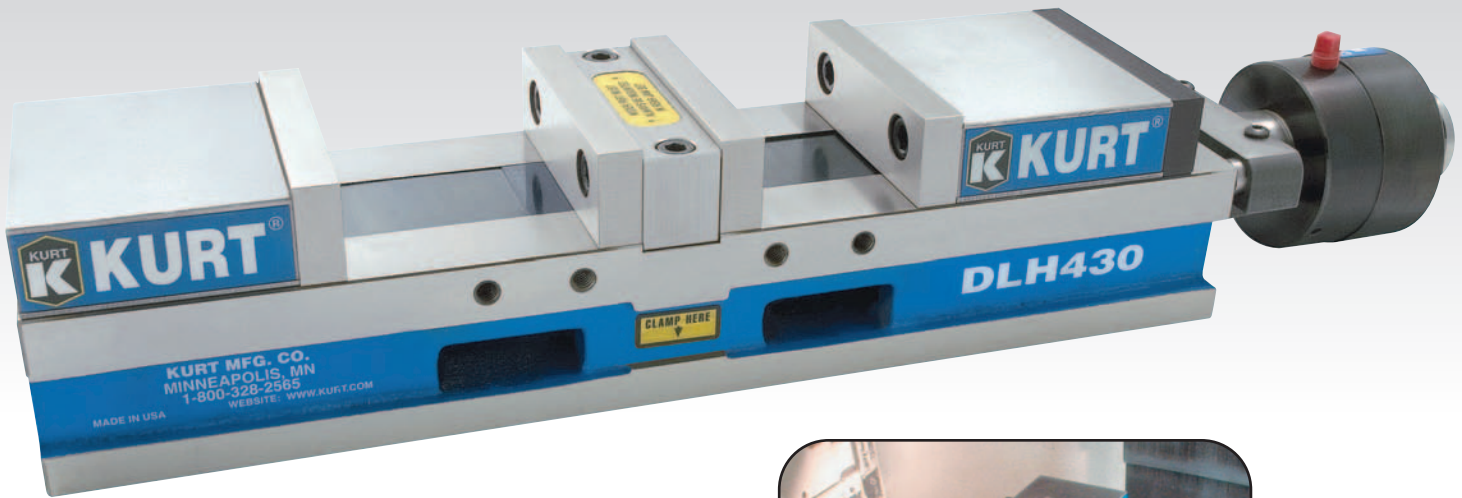

The DLH430 and DLH800 hydraulic DoubleLock vises from Kurt offer two clamping stations with a part capacity of 3" x 4" (DLH430) and 6" x 8" (DLH800). The hydraulic DoubleLock vise provides repeatable clamping (0.002") for high accuracy machining and handles a higher horsepower cut than the manual version. The compact design features a wide range of clamping forces up to 12,600 lbs. 1/4" stroke - 1/8" per side.

- Productivity – multiple part workholding for better spindle utilization, reduced tool change time, and reduced machine travel from part to part.
- Durability – 80,000-PSI ductile iron body and steel components provide strength, rigidity and long term accuracy while absorbing machining vibration.

Intensifier, APD50-112, available in either hand (APD50-112-Hand) or foot (APD50-112-Foot) option. Purchase separately for the DLH430. Each vise must have it's own intensifier. Consult factory for the DLH800 model.

JAW POSITIONS

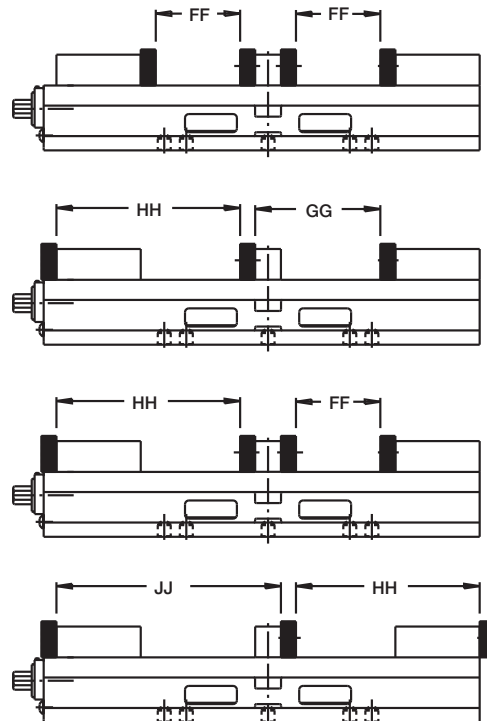

DOUBLELOCK® VISES

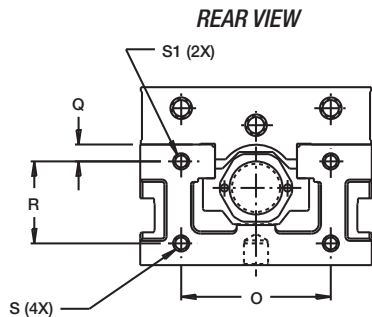
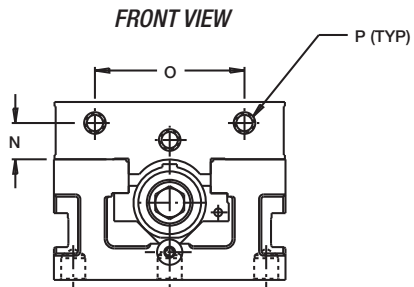
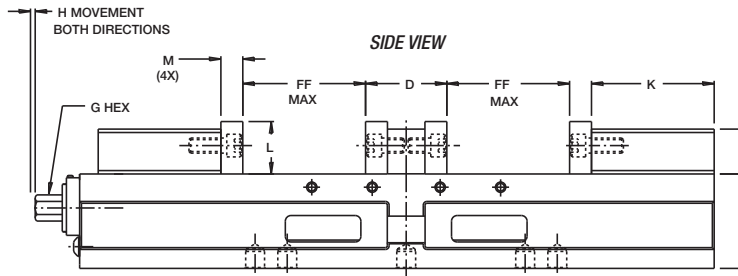
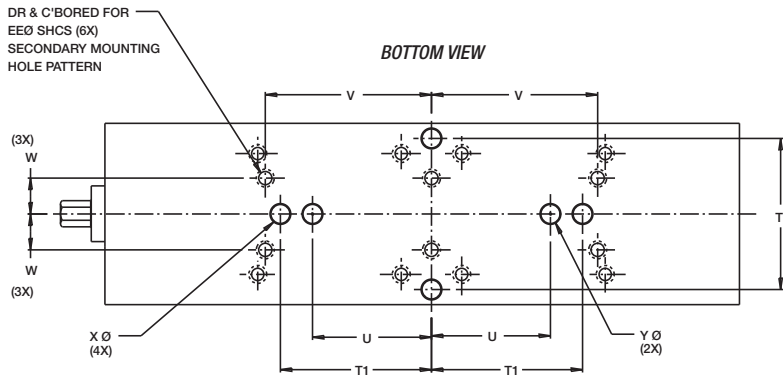
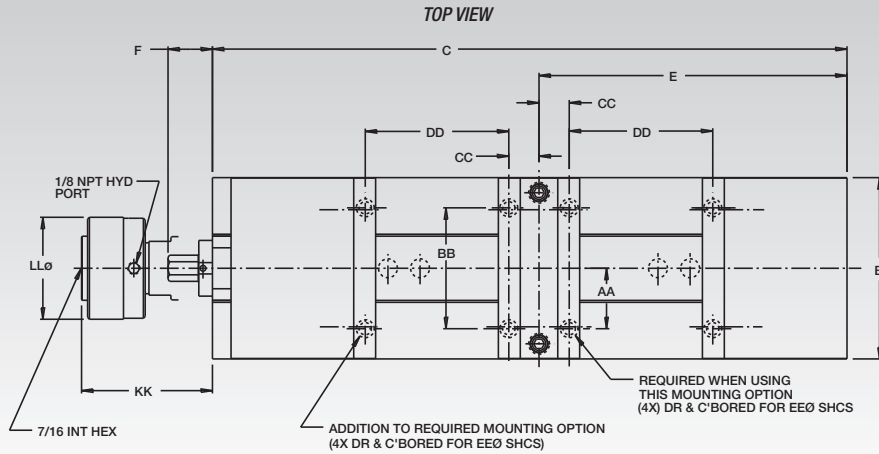

VISE CLAMPING FORCE-LBS.		
Hydraulic PSI Max.	DLH430	DLH800
400	1310	1575
800	2600	3150
1200	3900	4725
1600	5200	6300
2000	6550	7875
2400	7850	9450

DIMENSIONAL DATA		
	DLH430	DLH800
A	2.375	3.750
B	4.000	8.060
C	15.812	30.000
D	2.094	4.000
E	7.750	15.000
F	-	-
G	-	-
H	0.160	0.190
J	1.115	1.965
K	3.090	6.000
L	1.235	2.200
M	0.547	1.075
N	0.687	1.220
O	2.500	4.750
P	3/8-16	5/8-11
Q	0.375	0.750
R	1.688	2.375
S	5/16-18	1/2-13
S1	-	5/8-11
T	3.000	7.000
T1	5.000	7.000
U	3.397	-
V	3.750	8.000
W	0.813	3.625
X	0.625	0.750
Y	0.6299	-
AA	1.500	2.500
BB	3.000	5.000
CC	0.781	1.000
DD	3.625	7.500
EE	5/16	1/2
FF	3.000	6.000
GG	4.547	8.925
HH	6.637	13.075
JJ	8.184	16.000
KK	5.150	6.240
LL	2.938	3.375
Ship wt	50	360
Hyd Displacement cu. In.	1.47	2.36