

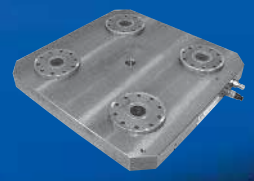

**VB DockLock Zero-Point  
Workholding Technology Systems**

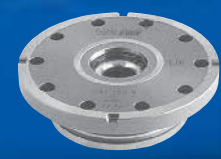



# Benefit from Our Full Line of Options.

The KURT 360° ADVANTAGE represents our complete precision manufacturing product offering. Gain powerful manufacturing advantages from hundreds of workholding options, custom designed options, automation, gaging systems, and so much more.

HD690 Vise



5 Axis Vise



Indexing Stations



Custom Workholding



PinLock Locating System



Zeropoint Docking System



Automation & Gaging



USB & Shop Computers



SPC Data Collection

Custom Gaging



KHP5000 Hydraulic Pump and cylinders



## VB DockLock Index

	Page
<b>VB DockLock Information</b> .....	2-4
The zero-point workholding system	
<b>VB DockLock</b> .....	5
The new collect lock (patented)	
<b>VB DockLock SAFE 20</b> .....	6-8
Flanged Cylinders	
<b>VB DockLock SAFE 20</b> .....	9
Built-in Cylinders	
<b>VB DockLock SAFE 20</b> .....	10
Built-up Cylinders	
<b>VB DockLock SAFE 20</b> .....	11
Standard built-up cylinder sets	
<b>VB DockLock SAFE 20</b> .....	12
The pneumatic activated version with the new collet lock (patented)	
<b>VB DockLock SAFE 20</b> .....	13
Recommended plug arrangement	
<b>VB DockLock SAFE 20</b> .....	14-15
Plugs	
<b>VB DockLock SAFE 20</b> .....	16
Accessories	
<b>VB DockLock SAFE 30 Cylinders</b> .....	17
with patented collet lock for direct integration into machining tables	
<b>VB DockLock SAFE 50 Cylinders</b> .....	18
with patented collet lock for direct integration into machining tables	
<b>VB DockLock SAFE 30/50</b> .....	19
Accessories	
Machine Check List	
<b>VB DockLock SAFE 20</b> .....	20-21
Standard 4 Unit Base Plates, 2 Unit Base Plates	
<b>VB DockLock SAFE 20</b> .....	22-23
Standard 4 Unit Base Plate Sets Standard 2 Unit Base Plate Sets	
<b>VB DockLock SAFE 20</b> .....	24-25
Standard pallets	
<b>VB DockLock</b> .....	26
Pressure pumps Automation with Safety-factor	

Call For more information on these additional KURT products:

Workholding Systems, Hydraulic Swing Clamps,

Electronic Gaging and Automation Systems,

1-877-226-7823

# VB DockLock

The **VB DockLock** system is a patented, zero-point workholding system for increasing productivity and reducing setup and changeover. The **VB DockLock** system integrates with new or existing workholding devices such as Kurt vises and fixtures, and provides fast, ultra accurate setup on machining centers. Time consuming setup, alignment and bolt down tasks are eliminated.

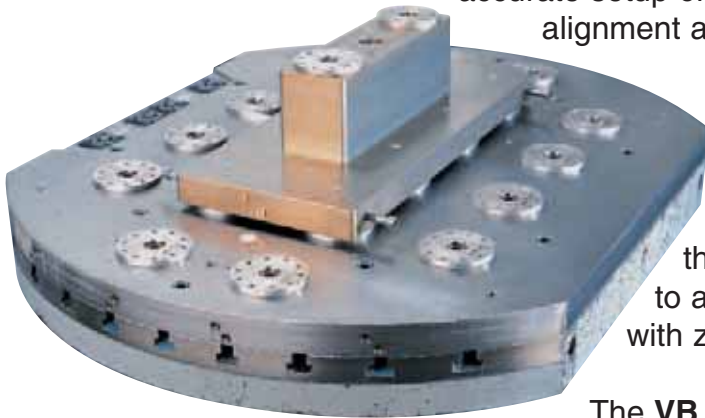

The system consists of a patented hydraulic actuated locking cylinder device that positions and locks the vise or fixture onto the machine worktable. It allows the user to locate or remove the workholding from a machine, or move it offline or to another machine and/or back again in just seconds with zero-point positioning accuracy every time.

The **VB DockLock** system is widely used throughout Europe and is produced to the highest Swiss standards. Kurt Manufacturing is the exclusive distributor and integrator in North America of the **VB DockLock** system for today's manufacturing.

## Comparison of average loss on set-up changes! (machining hour \$ 90.-)

### Conventional

#### a) Vise



**20 min.**  
**\$ 30.-**

#### b) Fixture



**40 min.**  
**\$ 60.-**

### with VB DockLock

#### a) Vise



**2 min.**  
**\$ 3.-**

#### b) Fixture



**2 min.**  
**\$ 3.-**

## Increased efficiency with VB DockLock zero-point workholding system (assumption 200 working days) Based on Published Averages

### a) with vise

savings \$27.00  
with every change

1 set-up change per day  
2 set-up changes per day  
4 set-up changes per day

1 machine  
1 shift

\$ 5,400  
\$ 10,800  
\$ 21,600

### savings in one year

5 machines  
1 shift

\$ 27,000  
\$ 54,000  
\$ 108,000

5 machines  
3 shifts

\$ 81,000  
\$ 162,000  
\$ 324,000

### b) with fixture

savings \$57.00  
with every change

1 set-up change per day  
2 set-up changes per day  
4 set-up changes per day

1 machine  
1 shift

\$ 11,400  
\$ 22,800  
\$ 45,600

### savings in one year

5 machines  
1 shift

\$ 57,000  
\$ 114,000  
\$ 228,000

5 machines  
3 shifts

\$ 171,000  
\$ 342,000  
\$ 684,000

## The leading zero-point workholding system on machining centers, proven in thousands of applications

### Advantages:

- Set-up changes parallel to machining .....
- Work interruption possible at any time without losing "zero point" .....
- Zero-point repeat accuracy  $\pm 0.0002"$ .....
- 5 - 6 face processing without unclamping .....
- Further usage of existing fixtures .....
- Inexpensive plug for clamping and centering .....
- Dynamical, form-fit clamping .....
- Cylinders for direct integration into machine tables .....
- Built-in cylinders .....
- Built-in cylinders .....

### Benefits:

- lowers machine down-times by 90% and increases productivity .....
- flexibility for urgent orders .....
- interruption anytime without losing the zero-point .....
- obstruction free machining .....
- huge time and cost savings .....
- simple mounting to fixtures, pallets or workpieces .....
- improved surfaces, increased tool life and high security .....
- no distortion forces in the machining table .....
- allow any configuration in spacing on plates, set-up tables and CMM's .....
- for a flexible arrangement on every machine .....

### Fixtures / workpieces

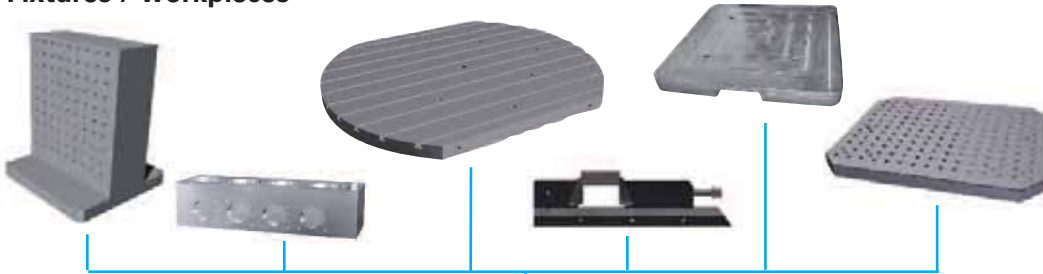

### Plug mounting



Integrated cylinders

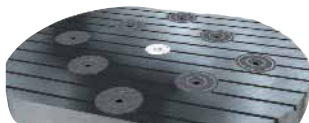

Machine level

Base plate with built-in cylinders



Built-up cylinders



## Flanged cylinders...

... avoid stress in machine tables and pallets  
allow any configuration



## Built-in cylinders...

... allow any configuration of base-plates, set-up stations,  
and measuring machines

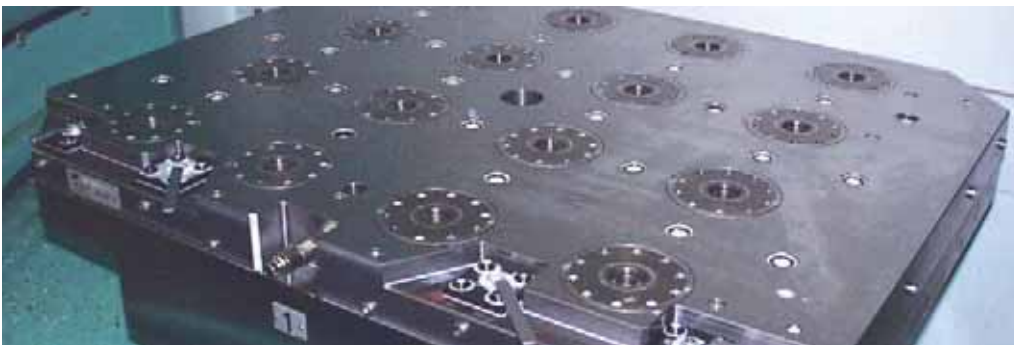

## Built-up cylinders ...

... for flexible array on machine tables, set-up stations  
and measuring machines



## The new cylinder with collet lock

The new generation clamping cylinders with collet-lock (patented) brings lots of advantages:

- form-fit connection between clamping cylinder, plug and workpiece
- improved vibration damping
- improved pull-in force (12,500 N / 2,800 lbs per cylinder)
- improved retention force
- the suspension function of the collet makes fixture-handling easy on vertical lay-outs
- less components, less susceptible to dirt
- easy to maintain, accessible from the top
- US Patent #6860477

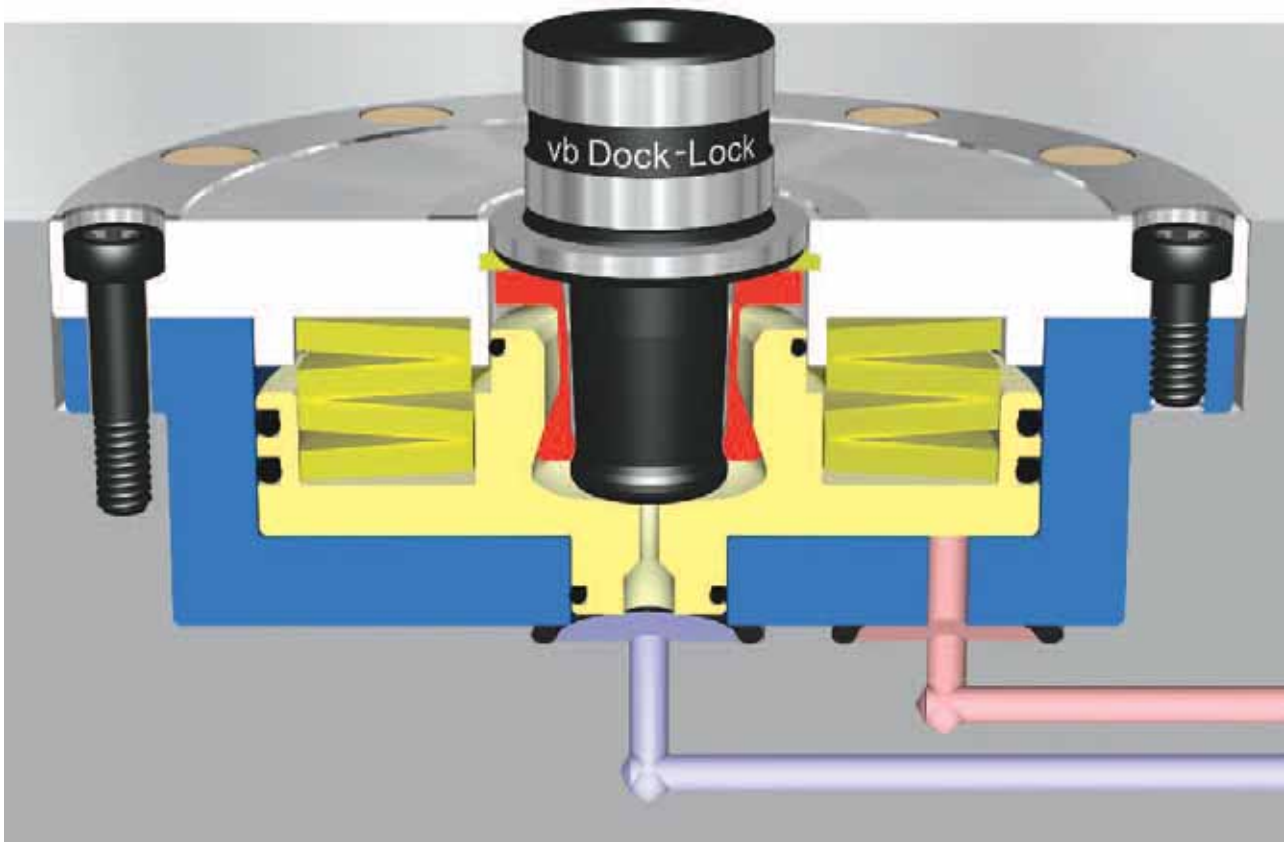

High pull-in and retention forces with the patented collet locking system

	pull-in force per unit	retention force per unit
<b>vb Dock</b> <sup>®</sup> SAFE 20 (1 Ton)	12'500 N (2800 lbs)	40'000 N (9,000 lbs)
<b>vb Dock</b> <sup>®</sup> SAFE 30 (2 Ton)	20'000 N (4500 lbs)	60'000 N (13,500 lbs)
<b>vb Dock</b> <sup>®</sup> SAFE 50 (3 Ton)	30'000 N (6750 lbs)	90'000 N (20,200 lbs)

# FLANGED CYLINDERS WITH COLLET LOCK

**VB DockLock SAFE 20** Flanged cylinders with patented collet lock for direct integration into machining tables, pallets and fixtures

- 752160** Standard
- 752160 L** with air-blast cleaning
- 752160 LU** with air-blast cleaning and rear side oil and air connection

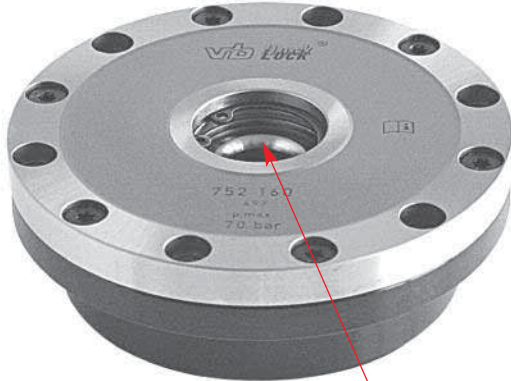

**For in-house mounting please ask for instructions!**

## 752160

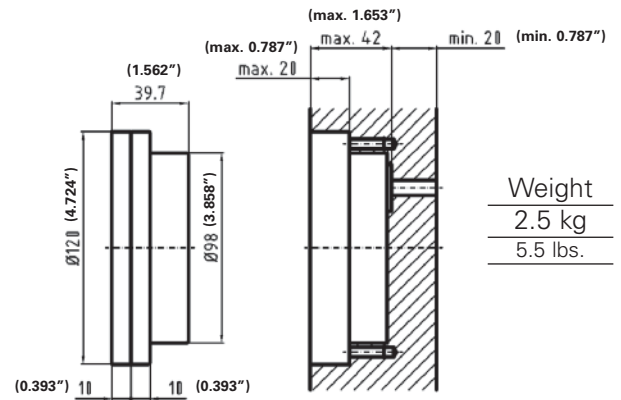

## 752160 L

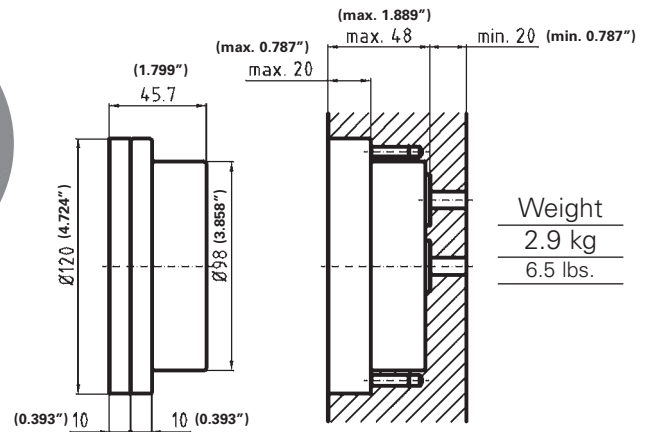

## 752160 LU

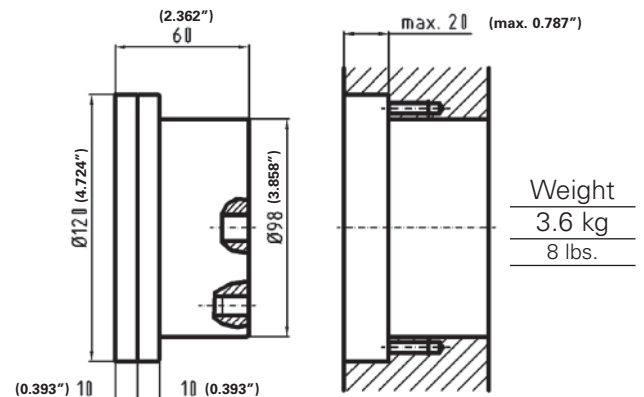



# FLANGED CYLINDERS WITH INDEXING GROOVES

**VB DockLock SAFE 20** Flanged cylinders with indexing grooves and patented collet lock for direct integration into machining tables, pallets and fixtures (for use with mini-basic pallets 751601 see page 24)

**752160 I**  
**752160 LI**  
**752160 LIU**

with indexing grooves  
with air-blast cleaning and indexing grooves  
with air-blast cleaning and indexing grooves, oil and air connection on rear side

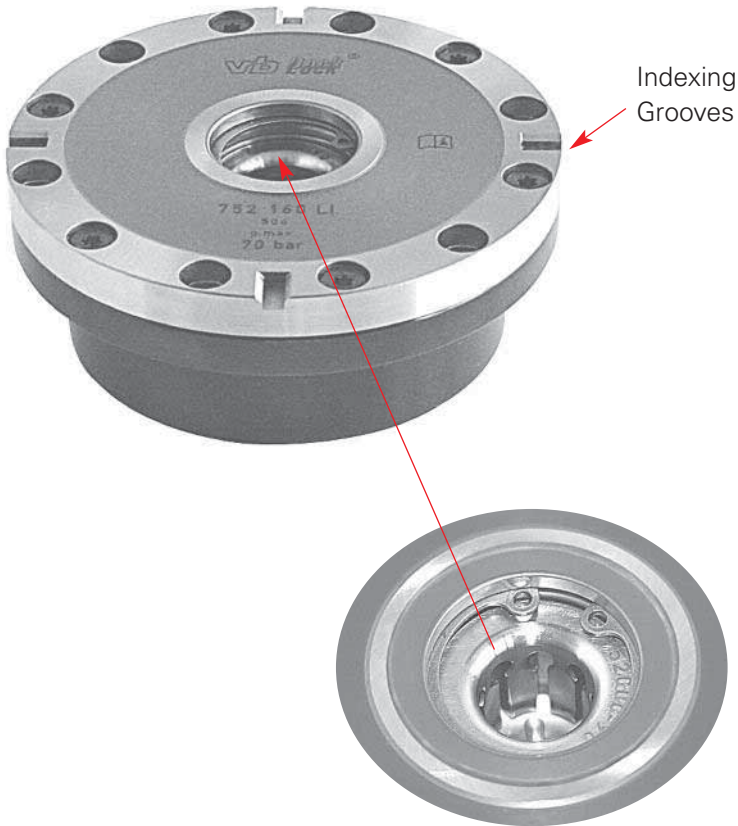

## 752160 I

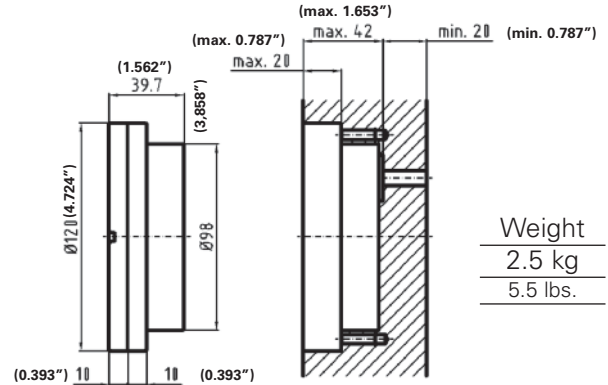

## 752160 LI

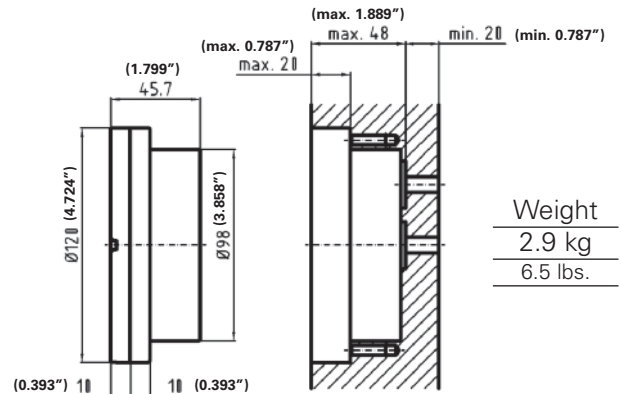

Use with Mini-basic pallet 751601 see page 24  
Use with Indexing set-screws see page 16

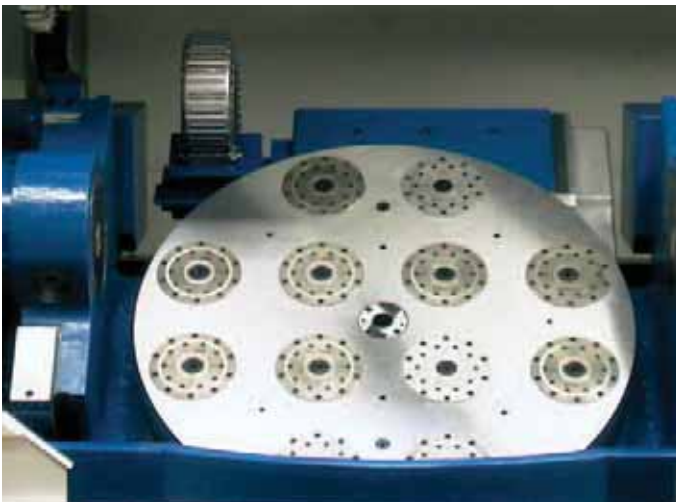

**For in-house mounting please ask for instructions!**

## 752160 LIU

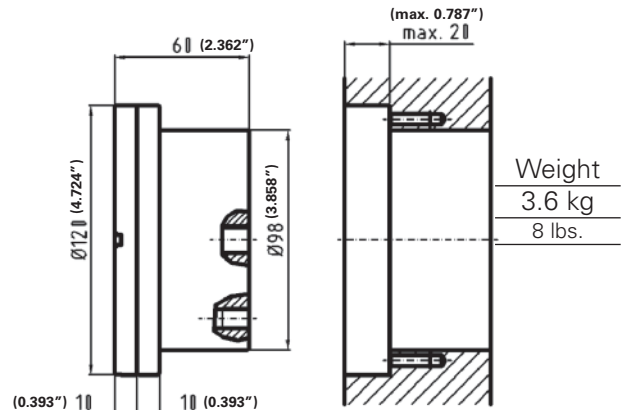

# FLANGED CYLINDERS WITH AIR-BLAST

**VB DockLock SAFE 20** Flanged cylinders with air-blast support isles and patented collet lock for direct integration into machining tables, pallets and fixtures

**752160 LA** with air-blast cleaning and air-blast support isles, oil and air connection by deep-hole drilling through the machining table

**752160 LAU** with air-blast cleaning and air-blast support isles, oil and air connection on rear side

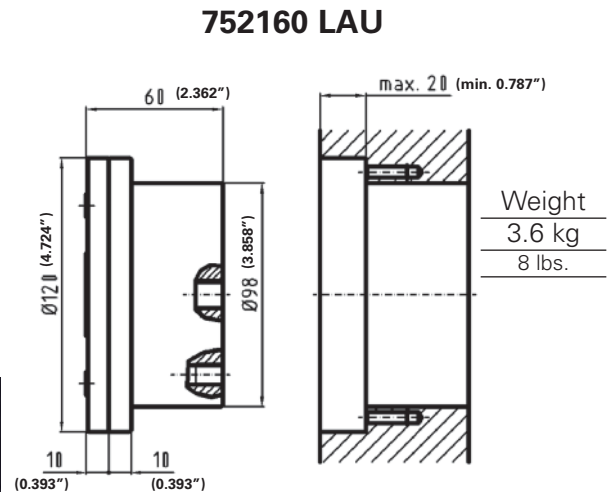
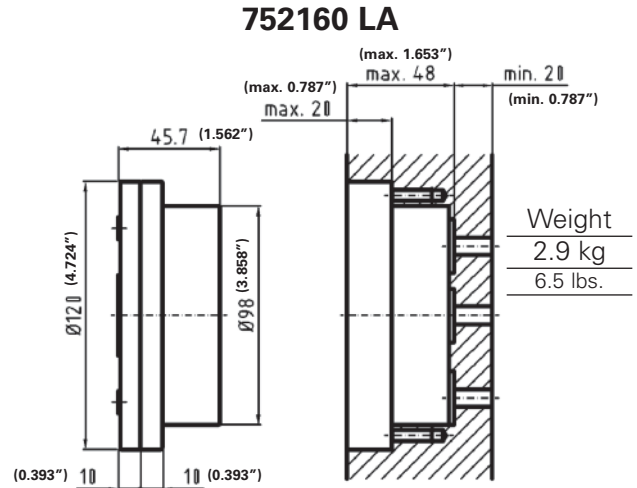
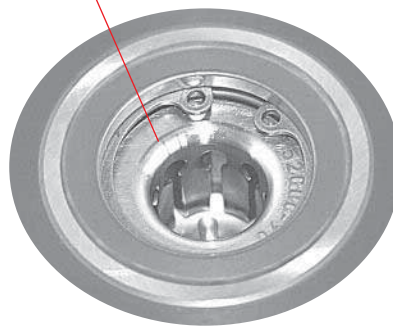

**For in-house mounting please ask for instructions!**

**VB DockLock SAFE 20** Built-in cylinder with patented collet lock

**752150** Standard  
**752150 L** with air-blast cleaning

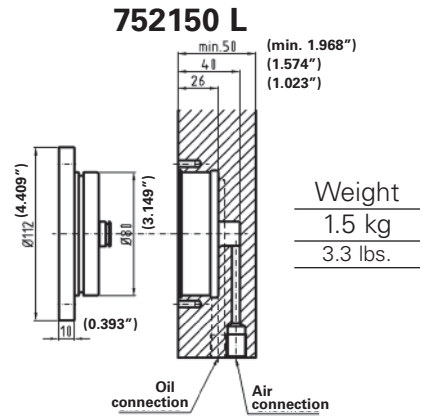
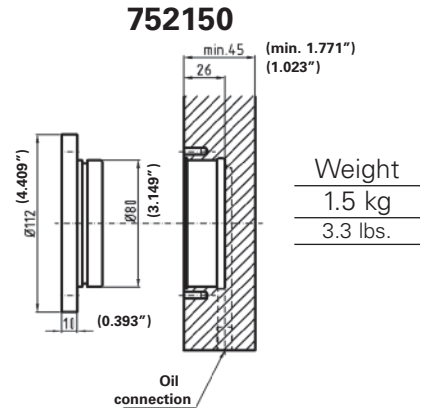
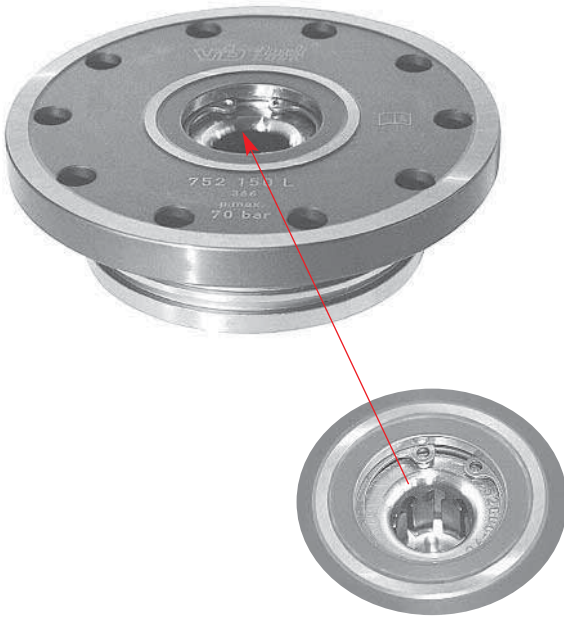

**For in-house mounting please ask for instructions!**

**752150 I** with indexing grooves  
**752150 LI** with indexing grooves and air-blast cleaning

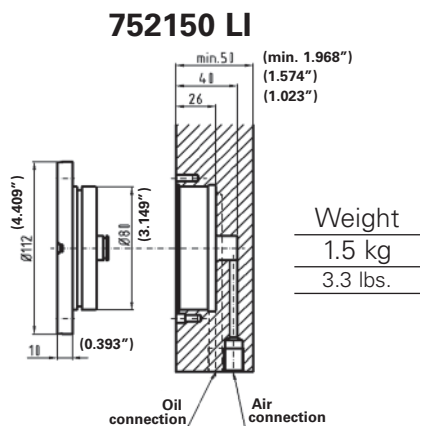
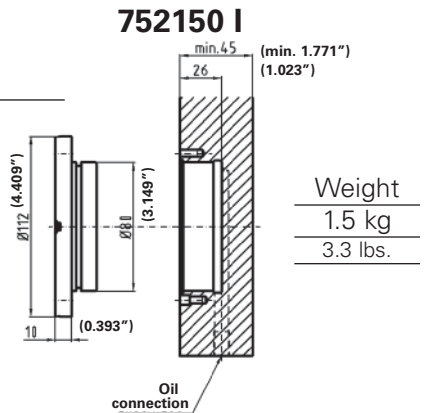

Mini-basic pallet 751601 see page 24  
 Indexing set-screws see page 16

**For in-house mounting please ask for instructions!**

# BUILT-UP CYLINDER WITH COLLET LOCK

**VB DockLock SAFE 20** Built-up cylinder with patented collet lock for flexible applications

**752110** Standard  
**752110 L** with air-blast cleaning (as shown)

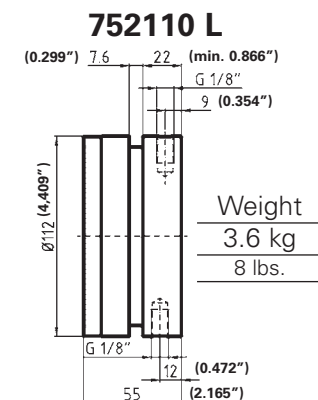
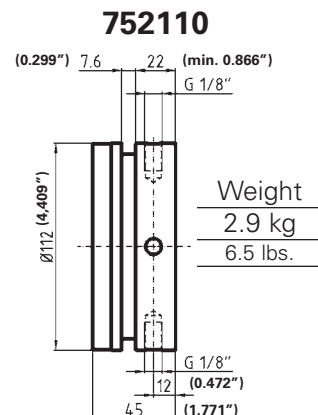
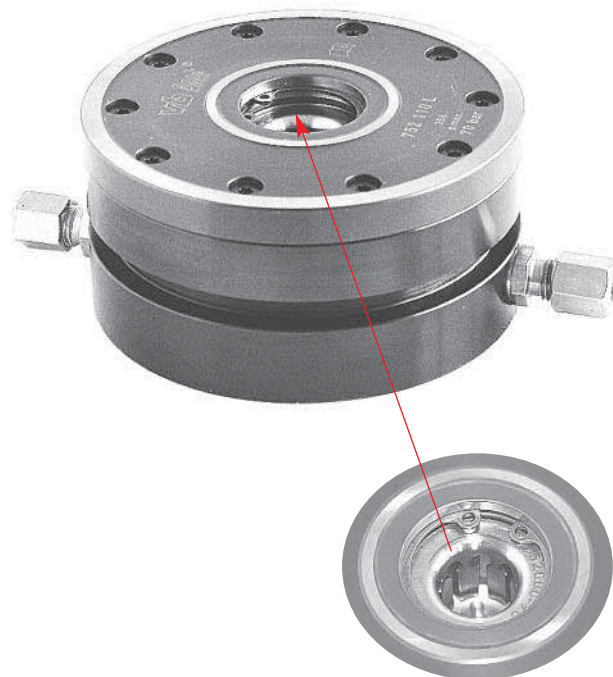

**752110 I** with indexing grooves (as shown)  
**752110 LI** with indexing grooves and air-blast cleaning

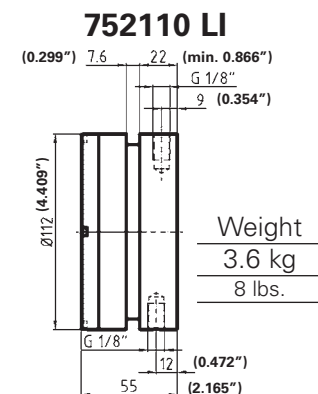
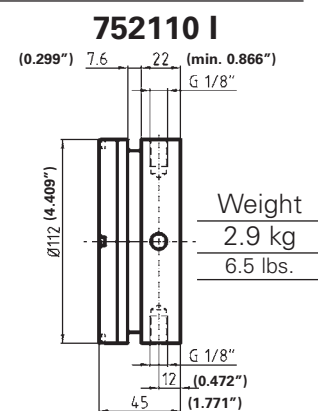
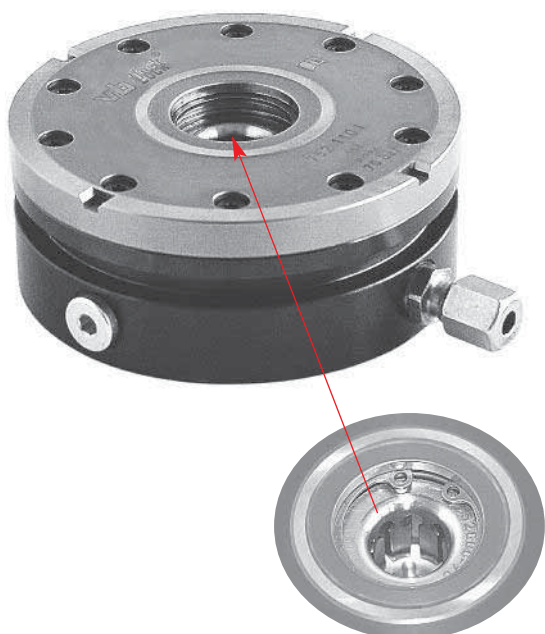

Mini-basic pallet 751601 see page 24  
 Indexing set-screws see page 16



# BUILT-UP CYLINDER SETS

**VB DockLock SAFE 20** Standard built-up sets with patented collet lock

<b>752020</b>	<b>4 pcs</b>	<b>Standard built-up cylinder</b> without air-blast cleaning	752110	
	<b>16 pcs</b>	<b>Brackets</b>	751172	
	<b>2 pcs</b>	<b>Centering plugs</b>	752500	
	<b>4 pcs</b>	<b>Plugs without centering</b>	752510	
	<b>2 pcs</b>	<b>Compensation plugs</b>	752520	
	<b>1 set</b>	<b>Pipework Oil</b>	758900	

<b>752021</b>	<b>4 pcs</b>	<b>Standard built-up cylinder</b> with air-blast cleaning	752110L	
	<b>16 pcs</b>	<b>Brackets</b>	751172	
	<b>2 pcs</b>	<b>Centering plugs for cylinders with air-blast cleaning</b>	752504	
	<b>4 pcs</b>	<b>Plugs without centering</b>	752510	
	<b>2 pcs</b>	<b>Compensation plugs</b>	752520	
	<b>1 set</b>	<b>Pipework Oil</b>	758900	
	<b>1 set</b>	<b>Pipework Air</b>	758903	

<b>752026</b>	<b>1 pce</b>	<b>Standard built-up cylinder</b> with indexing, without air-blast cleaning	752110	
	<b>4 pcs</b>	<b>Brackets</b>	751172	
	<b>2 pcs</b>	<b>Centering plugs</b>	752500	
	<b>2 pcs</b>	<b>Mini basic pallet, indexable, with</b>	751601	
	<b>each 4 pcs</b>	<b>Indexing set-screws, mounted</b>	751580	
	<b>1 set</b>	<b>Pipework Oil</b>	758901	

<b>752028</b>	<b>1 pce</b>	<b>Standard built-up cylinder</b> with indexing and air-blast cleaning	752110LI	
	<b>4 pcs</b>	<b>Brackets</b>	751172	
	<b>2 pcs</b>	<b>Centering plugs for cylinders with air-blast cleaning</b>	752504	
	<b>2 pcs</b>	<b>Mini basic pallet, indexable, with</b>	751601	
	<b>each 4 pcs</b>	<b>Indexing set-screws, mounted</b>	751580	
	<b>1 set</b>	<b>Pipework Oil</b>	758901	
	<b>1 set</b>	<b>Pipework Air</b>	758904	

Aluminum covers for cylinders: see page 16

**758800-1**  
Pressure pump, 220 Volt or 110 Volt  
please order separately (see page 26)

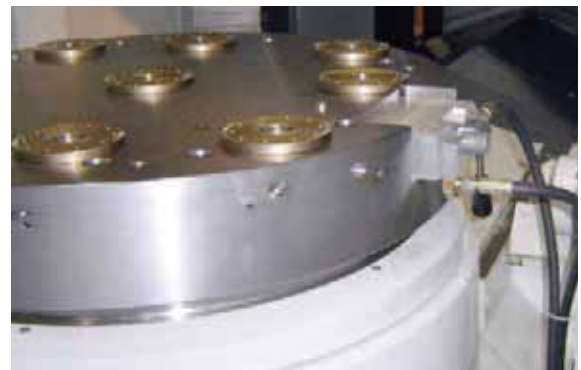

# CYLINDER WITH PNEUMATIC

**VB DockLock SAFE 20** The pneumatic activated version

**752P ... Pneumatic cylinders  
with collet lock** (patented)

**Flange cassettes, built-up and built-in cylinders are now available  
pneumatically activated  
(Pull-in and retention force depend on air pressure)**

**This version has been developed for:**

- **Set-up stations**
- **CMM's**
- **Light machining**
- **May be matched to specific air pressure requirements**
- **Factory set for 100 PSI Air Pressure (100 PSI = approx 280 lbs. Pull Down Force)**



## VB DockLock SAFE 20 Recommended plug arrangement



**Centering plugs**  
- ground  $\varnothing 32 \pm 0_{0,01}^0$  mm (1.2598")

The centering plugs defines the zero-point.  
It centers with a diameter of 32 mm. (1.2598")



**Compensation plug**  
- two ground,  
raised cams  $\varnothing 32 \pm 0_{0,01}^0$  mm (1.2598")

The compensation plug defines the X- or Y-axis.  
The came line must be set 90 ° to the line connecting with  
the centering plug. Compensates for variations in temperature.



**Plug without centering**  
-  $\varnothing 31.5 \pm 0_{0,1}^0$  mm (1.2401")

Plugs without centering only serve for clamping

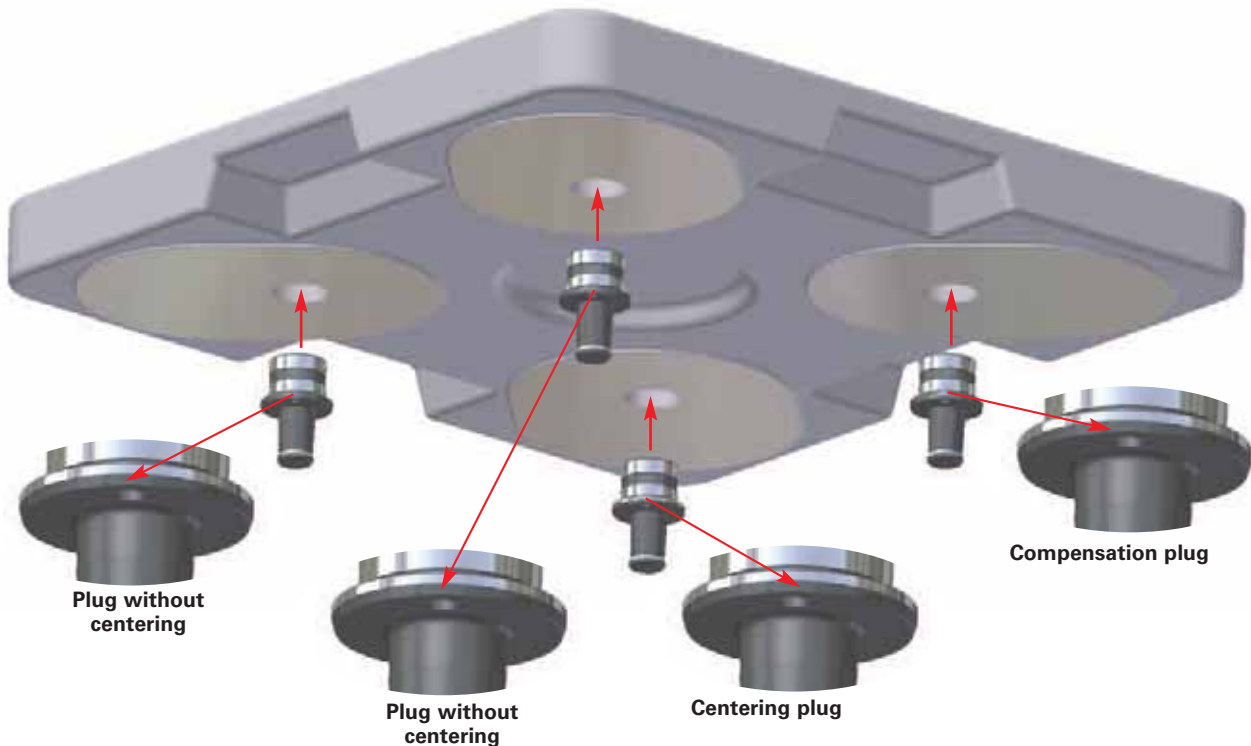

# SAFE PLUGS

## VB DockLock SAFE 20 Plugs

### Plug fitting versions: long plugs

### Plug fitting versions: short plugs

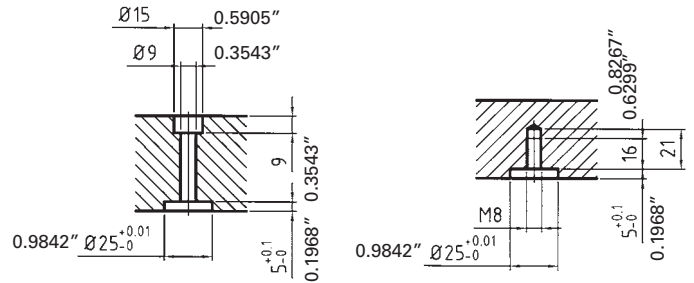
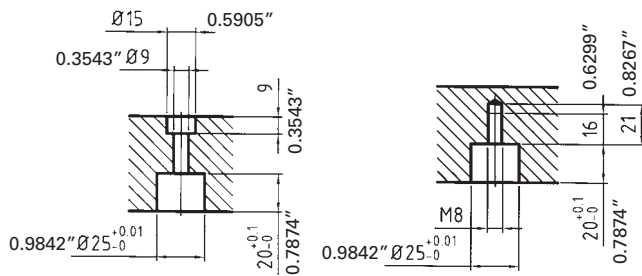

**752500 Centering plug, long**

Weight  
0.12 kg  
0.26 lbs.

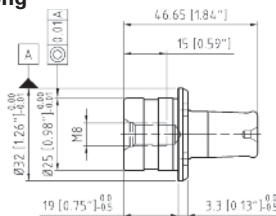
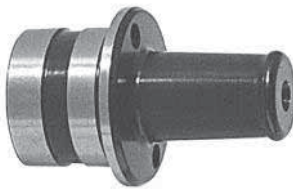

**752502 Centering plug, short**

Weight  
0.07 kg  
0.15 lbs.

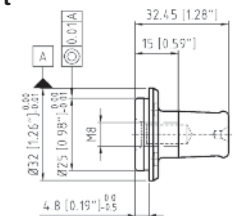

**752504 Centering plug, long for cylinders with air-blast cleaning**

Weight  
0.12 kg  
0.26 lbs.

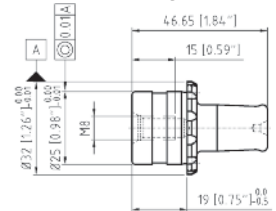

**752505 Centering plug, short for cylinders with air-blast cleaning**

Weight  
0.07 kg  
0.15 lbs.

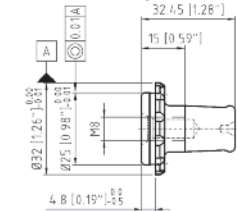

**752510 Plug without centering, long**

Weight  
0.12 kg  
0.26 lbs.

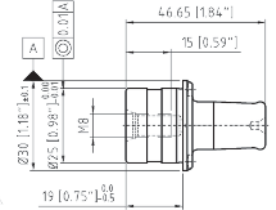

**752512 Plug without centering, short**

Weight  
0.07 kg  
0.15 lbs.

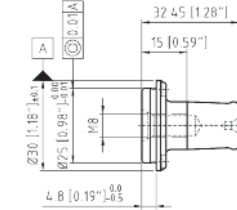

**752520 Compensation plug, long**

Weight  
0.12 kg  
0.26 lbs.

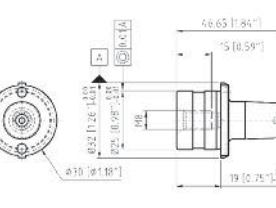
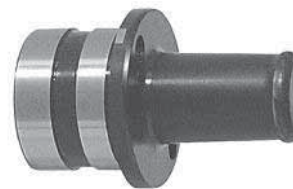

**752522 Compensation plug, short for cylinders with air-blast cleaning**

Weight  
0.07 kg  
0.15 lbs.

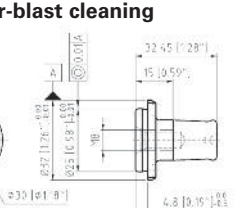

M8 (0.3150) tightening torque for plug mounting = 25 Nm (18.44 ft. lbs)

## VB DockLock SAFE 20 Plugs

**752523 Compensation plug, two parts, for blind hole mounting**

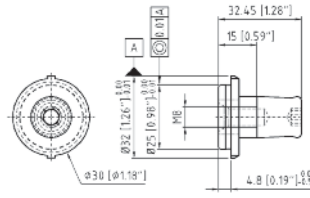

Weight  
0.07 kg  
0.15 lbs.

**752515 Centering plug for cylinders with air-blast cleaning, for machine vises**

Weight  
0.09 kg  
0.2 lbs.

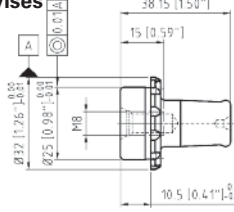

**752516 Centering plug for machine vises**

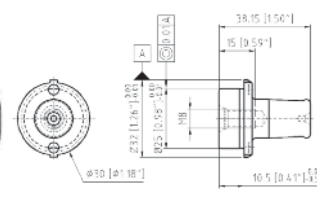

Weight  
0.09 kg  
0.2 lbs.

**752534 Cover plug**

Weight  
0.05 kg  
0.11 lbs.

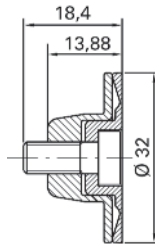

# VB DockLock Accessories

## VB DockLock SAFE 20 Accessories

**751590 Set-up plug for built-up cylinder**

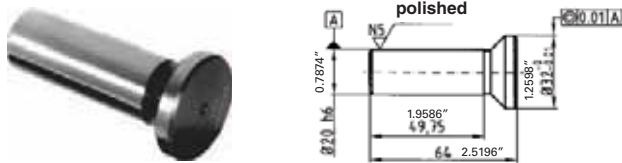

**751570 Blind Hole Mounting adapter for plugs**

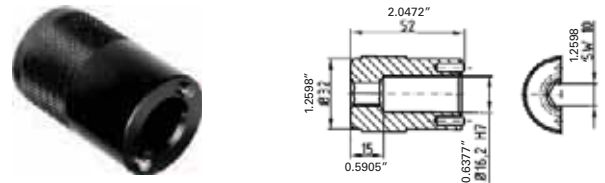

**75200090 Collet**

Collet assembly including circular spring 75100094



**751159 Aluminum cover**

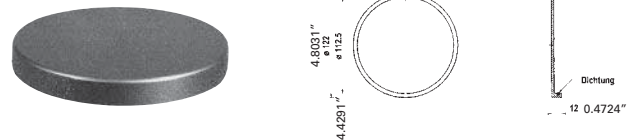

**751580 Indexing set-screw M8 (12.9) hardened, for Mini basic pallet 753 601**

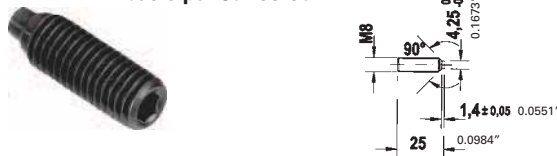

**751172 Bracket**

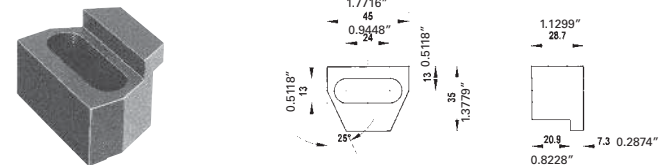

**752165K**

Spacers used to compensate height variations on flanged cylinder cavities SAFE 20. Thickness 2 mm

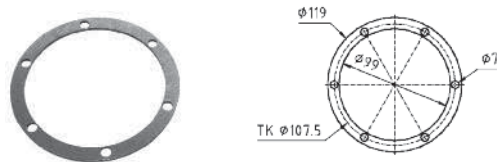

**758812 Coupling plug G 1/4" Oil**



**758813 Coupling collar G 1/4" Oil**



**75199... Brass cover disc for automated cylinders**



**751997**  $\varnothing$  8.5  $\pm$  0.05 mm 0.3346" 1 mm thickness 0.0393"

**751998**  $\varnothing$  10.5  $\pm$  0.05 mm 0.3346" 1 mm thickness 0.0393"

**751999**  $\varnothing$  8.55  $\pm$  0.10 mm 0.3346" 1 mm thickness 0.0393"

**Protection cover for counterbores on VB DockLock cylinders**

**Attention:**  
Important for automated application.

**Fitting:**  
Fit flush by using a plastic-faced hammer.

**Removal:**  
Strike the center with a small punch and pull out with a scriber or similar tool.

**758800-1**

**Pressure pump**  
**Oil volume:** 2 l  
**Input:** 220 Volt or 110 Volt  
**Output:** 65 bar oil pressure  
**recommended:** for 1 to 20 cylinders SAFE 20  
for 1 to 8 cylinders SAFE 30/50



recommended hydraulic oil: ISO-VG32-46

**75100091 Circlip**





# FLANGED CYLINDERS

**VB DockLock SAFE 30** Flanged Cylinders  
 with patented collet lock for direct integration  
 into machining tables, pallets, and fixtures  
 Build-up cylinder for easy mounting

**Pull-in force:** 20,000 N, 4,500 LBS  
**Holding-force:** 60,000 N, 13,500 LBS

**752172** Standard  
**752172 L** with air-blast cleaning  
**752172 LU** with air-blast cleaning and rear side  
 oil and air connection

**752172 I** with indexing grooves  
**752172 LI** with air-blast cleaning and indexing grooves  
**752172 LIU** with air-blast cleaning and indexing grooves,  
 oil and air connection on rear side



**752702** Centering plug  
**752712** Plug without centering  
**752722** Compensation plug

Weight  
 0.16 kg  
 .35 lbs.

### Plug fitting versions

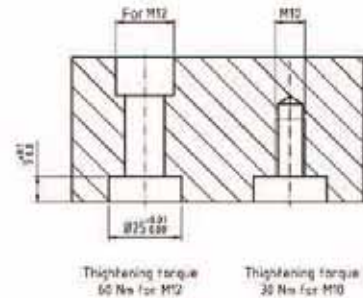

**752172**  
**752172 I**

**752172 L**  
**752172 LI**

**752172 LU**  
**752172 LIU**

**Build-up cylinder**  
**752178 L**  
**752178 LI**

Weight  
 6.6 kg  
 15 lbs.

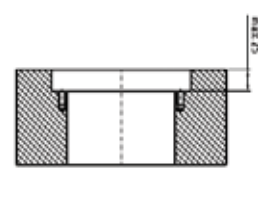
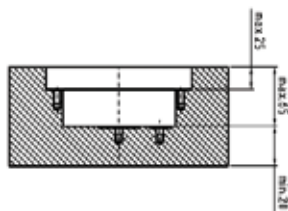
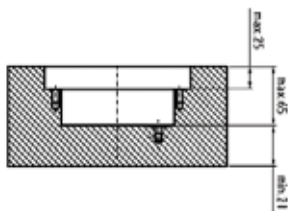
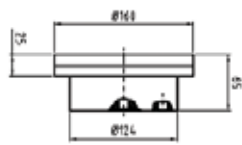
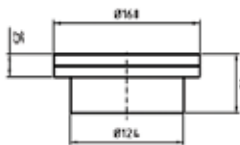
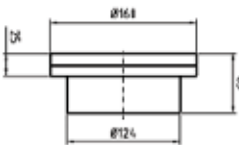

For in-house mounting please ask for instructions!

# FLANGED CYLINDERS

**VB DockLock SAFE 50 Flanged Cylinders**  
**with patented collet lock for direct integration**  
**into machining tables, pallets, and fixtures**  
**Build-up cylinder for easy mounting**

**Pull-in force:** 30,000 N, 6,750 LBS  
**Holding-force:** 90,000 N, 20,200 LBS

**753172** Standard  
**753172 L** with air-blast cleaning  
**753172 LU** with air-blast cleaning and rear side oil and air connection

**753172 I** with indexing grooves  
**753172 LI** with air-blast cleaning and indexing grooves  
**753172 LIU** with air-blast cleaning and indexing grooves, oil and air connection on rear side



**753702** Centering plug  
**753712** Plug without centering  
**753722** Compensation plug

Weight  
 0.16 kg  
 .35 lbs.

### Plug fitting versions

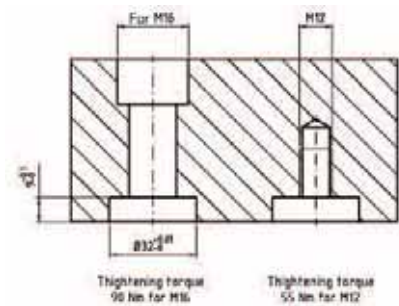

**753172**  
**753172 I**

**753172 L**  
**753172 LI**

**753172 LU**  
**753172 LIU**

### Build-up cylinder

**753178 L**  
**753178 LI**

Weight  
 12 kg  
 26 lbs.

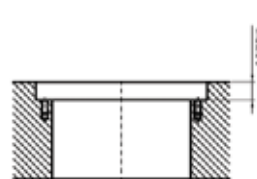
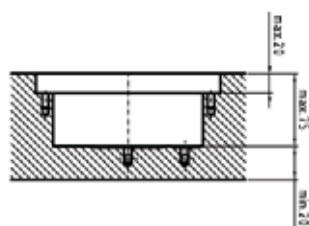
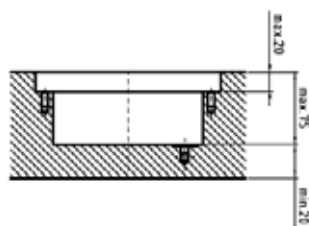
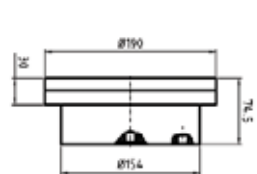
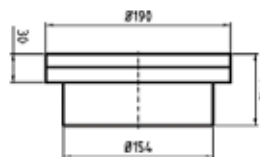

**For in-house mounting please ask for instructions!**

## VB DockLock Accessories for:

	SAFE 30	SAFE 50
<i>Collet assembly including circular spring 75100094</i>		



75200090 Collet    75200090 Collet

*Mini-basic pallet for cylinders with indexing. Comes with mounted indexing set screws.*



	752601	753601
	250mm x 250mm	250mm x 250mm
	Pitch circle	Pitch circle
	157 mm	187mm

*Indexing set screw*



	753580	753580
	M10	M10

*Socket head screw for plug mounting*



	752551	753551
	M10 x 40 mm	M12 x 50 mm
	(12.9)	(12.9)

*Low head socket screw for flanged cylinder mounting*



	753555	753556
	M6 x 30 mm	M8 x 40 mm

*Brass disc to cover screw head*



	752998	753999
	Ø 10,5 x 1 mm	Ø 13,5 x 1 mm

*Spacer compensating flanged cylinder cavity heights*



	752167	753165
	D / Ø159 / Ø124,6	D / Ø189 / Ø155
	H = 4 mm	H = 4 mm

*Bracket*



	753170	753170

*Setup plug for built-up cylinder*



	753590	753590

## VB DockLock Machine checklist

The following machine dimensions are helpful to obtain optimal results with the VB DockLock workholding system

### Vertical spindle

#### Machine tool table

- A: Machine tool table width
- B: Machine tool table length
- C: Obstructing edge diameter
- E: Distance of slot from table edge
- F: Slot distance
- G: Minimum distance; machine upright to machine tool table
- K: Slot with
- X: Traverse path in X-direction
- Y: Traverse path in Y-direction
- Z: Traverse path in Z-direction
- T: max. workpiece height

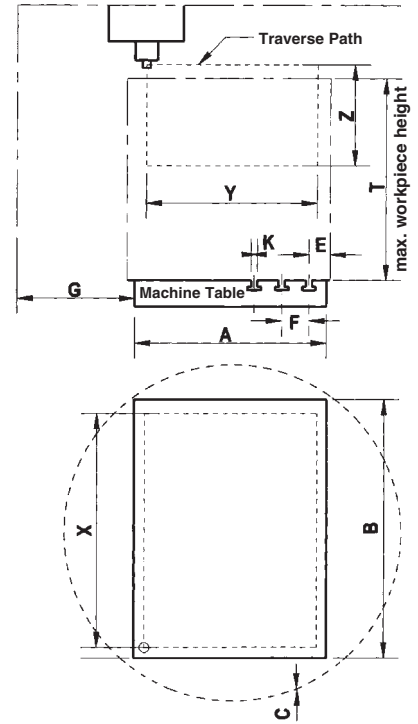

### Horizontal spindle

#### Machine tool table

- A: Machine tool table width
- B: Machine tool table length
- C: Obstructing edge diameter
- E: Distance of slot from table edge
- F: Slot distance
- G: Minimum distance; machine upright to machine tool table
- K: Slot with
- X: Traverse path in X-direction
- Y: Traverse path in Y-direction
- Z: Traverse path in Z-direction
- T: max. workpiece height

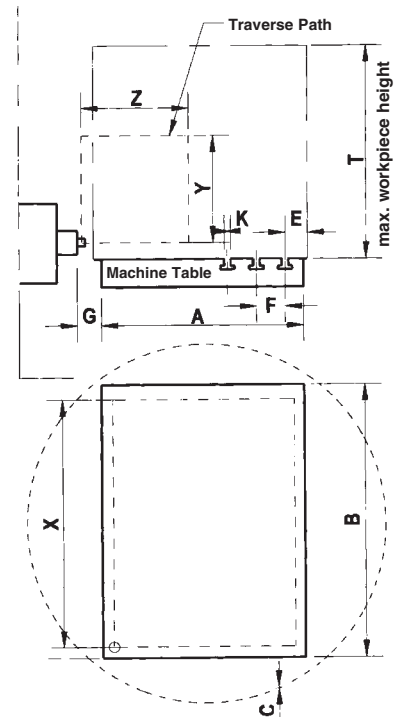

# STANDARD BASE PLATES

**VB DockLock SAFE 20** Standard base plates  
**4 unit plate**  
**built-in cylinders with patented collet lock**  
**and air-blast cleaning**

**752200**  
**752250**

Air fitting not included

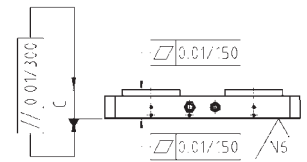
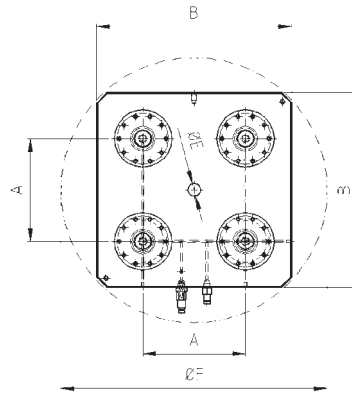
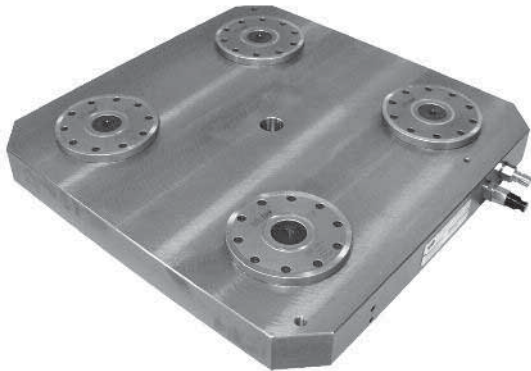

	A (Spacing)	B	C	E	F	Weight
752200	200 x 200 mm±0,01 (7.874" x 7.874")	380 x 380 mm (14.960" x 14.960")	55 mm ±0,01 (2.165")	25 mm H6 (0.984"H6)	518 mm (20.393")	48.5 kg 107 lbs.
752250	250 x 250 mm±0,01 (9.842" x 9.842")	445 x 445 mm (17.519" x 17.519")	55 mm ±0,01 (2.165")	25 mm H6 (0.984"H6)	610 mm (24.015")	72 kg 159 lbs.

**4 unit plate**  
**built-in cylinders with patented collet lock**  
**without air-blast cleaning**  
**TOE Clamp Slots** (brackets on page 16) #751172

**752205**  
**752255**

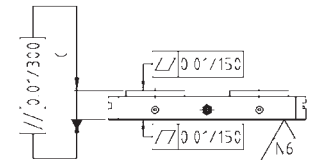
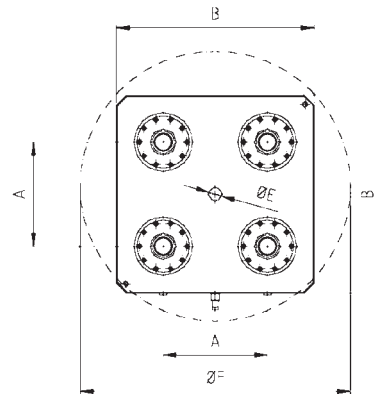
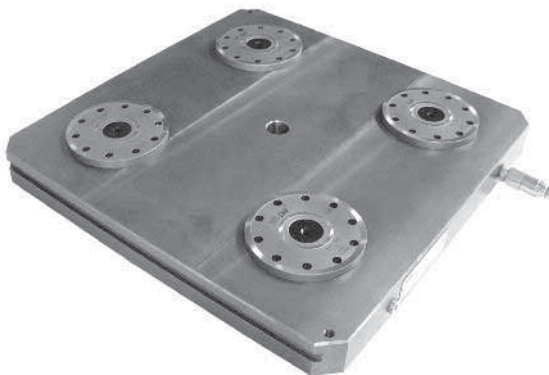

	A (Spacing)	B	C	E	F	Weight
752205	200 x 200 mm±0,01 (7.874" x 7.874")	380 x 380 mm (14.960" x 14.960")	55 mm ±0,01 (2.165")	25 mm H6 (0.984"H6)	518 mm (20.393")	48.5 kg 107 lbs.
752255	250 x 250 mm±0,01 (9.842" x 9.842")	445 x 445 mm (17.519" x 17.519")	55 mm ±0,01 (2.165")	25 mm H6 (0.984"H6)	610 mm (24.015")	72 kg 159 lbs.



# STANDARD BASE PLATES

**VB DockLock SAFE 20** Standard base plates  
**2 unit plate**  
**built-in cylinders with patented collet lock**  
**and air-blast cleaning**

**752220**

Air fitting not included

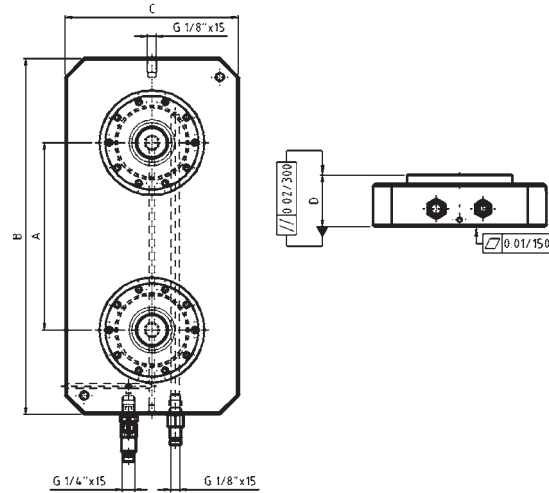
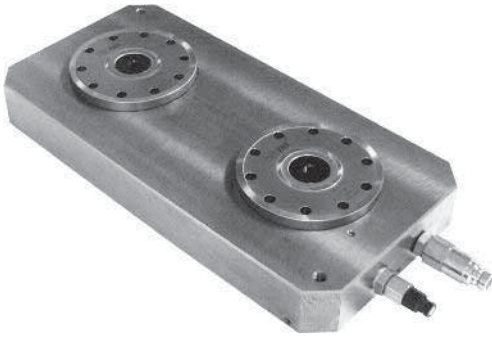

	A (Spacing)	B x C	D	Weight
752220	200 mm $\pm 0.01$ (7.874")	380 x 185 mm $\pm 0.2$ (14.960" x 7.283")	55 mm $\pm 0.01$ (2.165")	25.2 kg 55 lbs.

**2 unit plate**  
**built-in cylinders with patented collet lock**  
**without air-blast cleaning**  
**TOE Clamp Slots** (brackets on page 16) #751172

**752225**

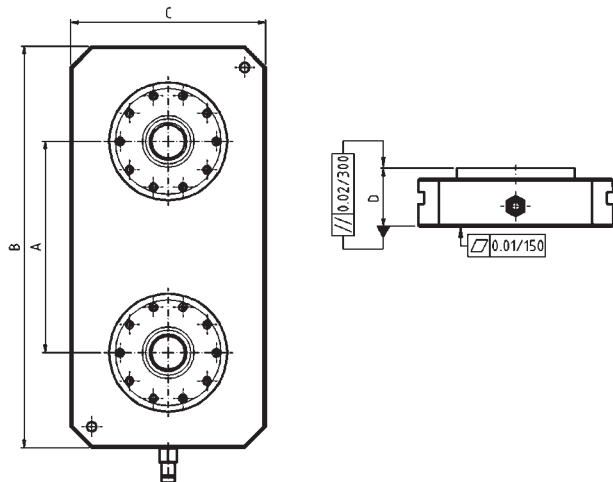

	A (Spacing)	B x C	D	Weight
752225	200 mm $\pm 0.01$ (7.874")	380 x 185 mm $\pm 0.2$ (14.960" x 7.283")	55 mm $\pm 0.01$ (2.165")	25.2 kg 55 lbs.

# STANDARD BASE PLATE SETS

**VB DockLock SAFE 20** Standard 4 unit base plate sets with patented collet lock

<b>752202</b>	<b>1 pce</b>	<b>Standard base plate</b> Spacing 200 x 200 mm (7.874" x 7.874") 4 units, with air-blast cleaning	752200
	<b>2 pcs</b>	<b>Centering plugs for cylinders with air-blast cleaning</b>	752504
	<b>4 pcs</b>	<b>Plugs without centering</b>	752510
	<b>2 pcs</b>	<b>Compensation plugs</b>	752520
	<b>4 pcs</b>	<b>Cover plugs</b>	752532
<b>752252</b>	<b>1 pce</b>	<b>Standard base plate</b> Spacing 250 x 250 mm (9.842" x 9.842") 4 units, with air-blast cleaning	752250
	<b>2 pcs</b>	<b>Centering plugs for cylinders with air-blast cleaning</b>	752504
	<b>4 pcs</b>	<b>Plugs without centering</b>	752510
	<b>2 pcs</b>	<b>Compensation plugs</b>	752520
	<b>4 pcs</b>	<b>Cover plugs</b>	752532
<b>752207</b>	<b>1 pce</b>	<b>Standard base plate</b> Spacing 200 x 200 mm (7.874" x 7.874") 4 units, without air-blast cleaning	752205
	<b>2 pcs</b>	<b>Centering plugs</b>	752500
	<b>4 pcs</b>	<b>Plugs without centering</b>	752510
	<b>2 pcs</b>	<b>Compensation plugs</b>	752520
	<b>4 pcs</b>	<b>Cover plugs</b>	752530
<b>752257</b>	<b>1 pce</b>	<b>Standard base plate</b> Spacing 250 x 250 mm (9.842" x 9.842") 4 units, without air-blast cleaning	752255
	<b>2 pcs</b>	<b>Centering plugs</b>	752500
	<b>4 pcs</b>	<b>Plugs without centering</b>	752510
	<b>2 pcs</b>	<b>Compensation plugs</b>	752520
	<b>4 pcs</b>	<b>Cover plugs</b>	752530

Picture shows set 752202



**2 pcs Centering plugs for cylinders with air-blast cleaning**  
**4 pcs Plugs without centering**  
**2 pcs Compensation plugs**  
**4 pcs Cover plugs**



**758800-1**  
**Pressure pump, 220 Volt or 110 Volt**  
**please order separately** (see page 26)





# STANDARD BASE PLATE SETS

**VB DockLock SAFE 20** Standard 2 unit base plate sets with patented collet lock

<b>752222</b>	<b>1 pce</b>	<b>Standard base plate</b> Spacing 200 mm (7.874") 2 units, with air-blast cleaning	752220
	<b>2 pcs</b>	<b>Centering plugs for cylinders with air-blast cleaning</b>	752504
	<b>2 pcs</b>	<b>Compensation plugs</b>	752520
	<b>2 pcs</b>	<b>Cover plugs</b>	752532
<b>752227</b>	<b>1 pce</b>	<b>Standard base plate</b> Spacing 200 mm (7.874") 2 units, without airblast-cleaning	752225
	<b>2 pcs</b>	<b>Centering plugs</b>	752500
	<b>2 pcs</b>	<b>Compensation plugs</b>	752520
	<b>2 pcs</b>	<b>Cover plugs</b>	752530



Picture shows set 752222

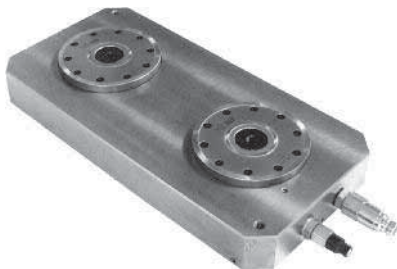

**2 pcs Centering plugs for cylinders with air-blast cleaning**  
**2 pcs Compensation plugs**  
**2 pcs Cover plugs**



**758800-1**  
**Pressure pump, 220 Volt or 110 Volt**  
**please order separately** (see page 26)



# STANDARD PALLETS

## VB DockLock *SAFE 20* Standard pallets

**751601**

Mini-basic pallet in high-strength aluminum for cylinders with indexing with plug bores, 4 indexing set-screws mounted

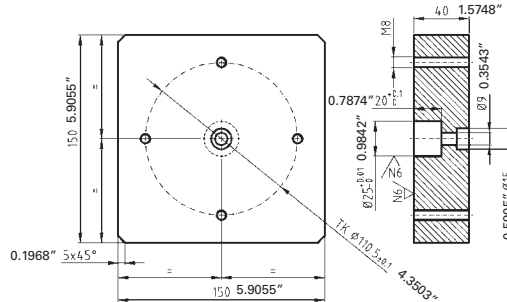

**751610**

Basic pallet in C45 steel  
4 plug bores  
top face raw machined  
plug bore face ground

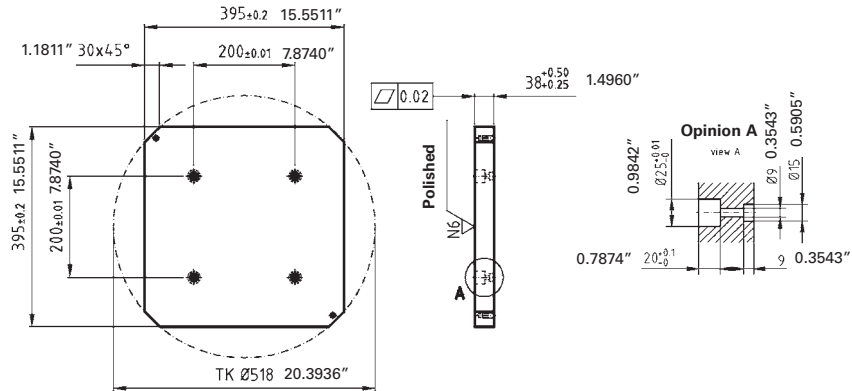

Weight
45 kg
99 lbs.

**751620**

Basic pallet in C45 steel  
half size, 2 plug bores  
top face raw machined  
plug bore face ground

Weight
20 kg
44 lbs.

**751621**

Basic pallet in high-strength aluminum  
half size, 2 plug bores  
top face raw machined  
plug bore face ground

Weight
7.6 kg
17 lbs.

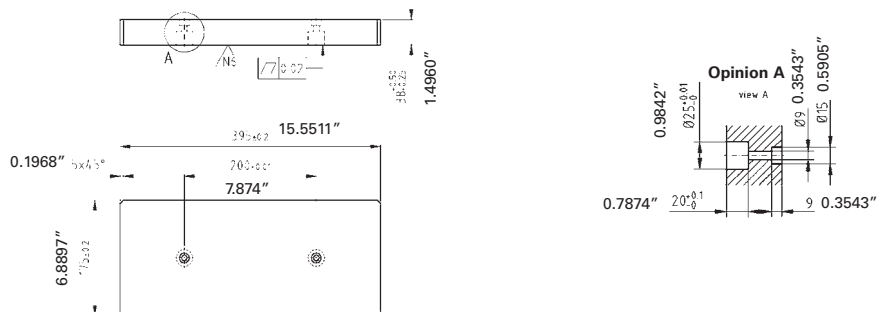



# STANDARD PALLETS

**751615**  
**VB DockLock**

Basic pallet in high-strength aluminum cast  
4 plug bores  
top face raw machined  
plug bore face finished

Weight  
15 kg  
33 lbs.

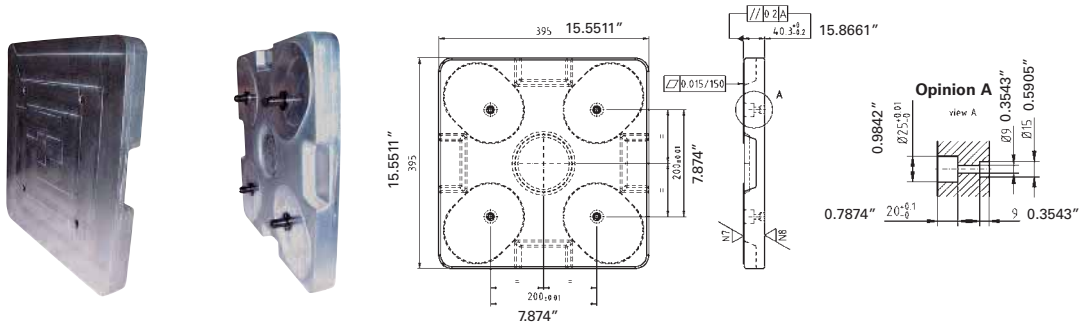

# PRESSURE PUMPS AND AUTOMATION

## VB DockLock Pressure pumps

<b>758800-1</b>	Oil volume:	2 l	<u>Weight</u> 15.7 kg 35 lbs.
	Input:	220 Volt or 110 Volt	
	Output:	65 bar oil pressure / 1015 PSI	
	recommended:	for 1 to 30 cylinders <b>SAFE 20</b> for 1 to 8 cylinders <b>SAFE 30 / 50</b>	
recommended hydraulic oil:	ISO-VG 32-46		

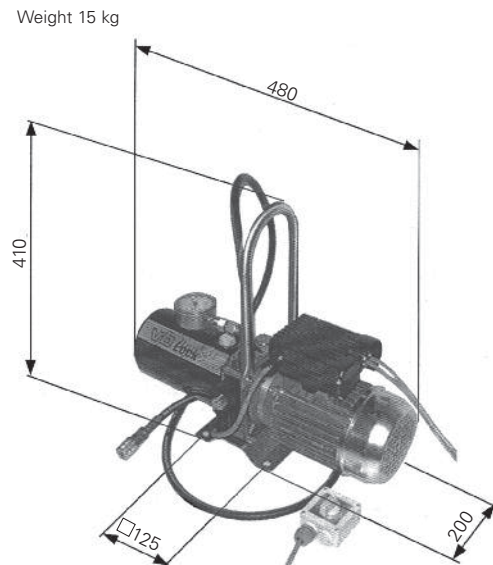

## 752170 ... Automation with safety-factor included!

The development of AUTO SAFE is a big breakthrough for the automation of zero-point workholding.

- The automated seal-off of the collet area eliminates soiling\*1
- Air blasted support isles leave remaining chips no chance \*2 / \*3
- Complete functional safety due to PEL support controls
- The suspension function of the collet makes fixture-handling easy on vertical lay-outs
- Form-fit connection of plug and collets result in more clamping power
- Easy pallet loading by pre-centering of the plug
- Easy serviceable, accessible from the top

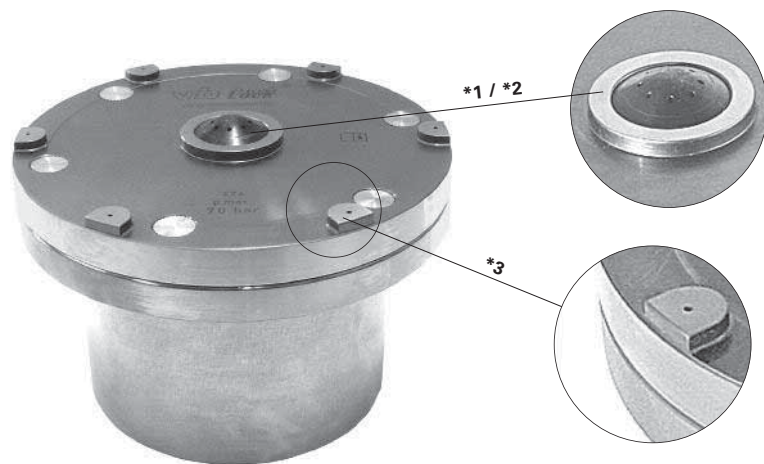

### AUTO SAFE 20

752 170-20	12,500 N / 2800 lbs per cylinder
Retention force	40,000 N / 9000 lbs per cylinder
Ø plug	20 mm (0.0787")
Diameter and height	120 x 70 mm (4.724" x 2.756")

### AUTO SAFE 30

752 170-30	20,000 N / 4500 lbs per cylinder
Retention force	60,000 N / 13500 lbs per cylinder
Ø plug	30 mm (0.1181")
Diameter and height	160 x 78 mm (6.299" x 3.071")

Pull-in force  
Retention force  
Ø plug  
Diameter and height



[www.kurtworkholding.com](http://www.kurtworkholding.com)

## **Kurt™ Manufacturing**

Industrial Products Division

9445 E. River Road NW

Minneapolis, MN 55433

Tel: (763) 574-8309

Fax: (763) 574-8313

Toll Free (US Only): 1 (877) 226-7823

Toll Free Fax (US Only): 1 (877) 226-7828

email address: [workholding@kurt.com](mailto:workholding@kurt.com)

website address: [www.kurtworkholding.com](http://www.kurtworkholding.com)

Kurt, AngLock, ArmLock, CarvLock, ClusterTower, D688, DLU4, DL430, DoubleLock, Groove Lock, InnerLock, Versatile Lock, SeraLock, CT430, CTU4 are registered trademarks of Kurt Manufacturing.

PowerLock and ToolBlox are trademarks of Kurt Manufacturing.

Printed in USA © Copyright. All rights reserved  
LIT.DL.0807.2

## **Distributor**



**Veteran Owned  
Made In America  
For Over 50 Years**